

# **St. Anne's college of Engineering and Technology**



***DEPARTMENT OF MECHANICAL ENGINEERING***

**Engineering Practices Laboratory**

**(GE3271)**

***REGULATION - 2021***

***LABORATORY MANUAL***

***PART-1 (CIVIL ENGINEERING PRACTICES)***  
***PART-3 (MECHANICAL ENGINEERING PRACTICES)***

**PART-3 MECHANICAL ENGINEERING PRACTICES**

**WELDING WORK:**

- a) Welding of Butt Joints, Lap Joints, and Tee Joints using arc welding.
- b) Practicing gas welding.

**BASIC MACHINING WORK:**

- a) (Simple) Turning.
- b) (Simple) Drilling.
- c) (Simple) Tapping.

**ASSEMBLY WORK:**

- a) Assembling a centrifugal pump.
- b) Assembling a household mixer.
- c) Assembling an air conditioner.

**SHEET METAL WORK:**

- a) Making of a square tray

**FOUNDRY WORK:**

- a) Demonstrating basic foundry operations.

**TOTAL = 15 PERIODS**

## **PART-1 CIVIL ENGINEERING PRACTICES**

### **PLUMBING WORK:**

- a) Connecting various basic pipe fittings like valves, taps, coupling, unions, reducers, elbows and other components which are commonly used in household.
- b) Preparing plumbing line sketches.
- c) Laying pipe connection to the suction side of a pump
- d) Laying pipe connection to the delivery side of a pump.
- e) Connecting pipes of different materials: Metal, plastic and flexible pipes used in household appliances.

### **WOOD WORK:**

- a) Sawing,
- b) Planing and
- c) Making joints like T-Joint, Mortise joint and Tenon joint and Dovetail joint.

### **Wood Work Study:**

- a) Studying joints in door panels and wooden furniture
- b) Studying common industrial trusses and models

**TOTAL = 15 PERIODS**

## LIST OF EXPERIMENTS

Ex. NO	CONTENTS	DATE	PAGE NO	REMARKS
	<b>WELDING</b>			
1	Butt Joint			
2	Lap Joint			
3	T-Joint			
	<b>BASIC MACHINING (LATHE)</b>			
4	Turning, Facing and Chamfering			
5	Taper turning			
6	Drilling and Tapping			
	<b>FOUNDRY &amp; SMITHY</b>			
	Demonstrating basic Foundry Operations			
	<b>SHEET METAL</b>			
7	Square Tray Making			
8	Funnel Making			
	<b>ASSEMBLY WORK</b>			
9	Centrifugal Pump			
10	House hold Mixer			
11	Air Conditioning			
	<b>PLUMBING WORK</b>			
12	Basic Connection Involving Pvc / Gi Pipes And Pipe Fittings			
13	Preparation Of Pipe Line From A Water Tank To Wash Basin			
14	Preparation Of Pipe Line From A Water Tank To Water Heater			
15	Preparation Of Pipe Line From A Water Tank To Washing Machine			
16	Laying pipe connection to the suction side of a pump			
17	Laying pipe connection to the delivery side of a pump.			
	<b>WOOD WORK</b>			
18	Planing and Sawing			
19	T-Lap Joint			
20	Dovetail Joint			
21	Mortise and Tenon Joint			
	<b>Wood Work Study:</b>			
	Studying joints in door panels and wooden furniture			
	Studying common industrial trusses using models.			

•

# WELDING

## **WELDING**

Welding is a fabrication process that joins materials, usually metals or thermoplastics, by causing coalescence. This is often done by melting the work pieces and adding a filler material to form a pool of molten material (the weld puddle) that cools to become a strong joint, with pressure sometimes used in conjunction with heat, or by itself, to produce the weld. This is in contrast with soldering and brazing, which involve melting a lower-melting-point material between the work pieces to form a bond between them, without melting the work pieces.

Many different energy sources can be used for welding, including a gas flame, an electric arc, a laser, an electron beam, friction, and ultrasound. While often an industrial process, welding can be done in many different environments, including open air, underwater and in space. Regardless of location, however, welding remains dangerous, and precautions must be taken to avoid burns, electric shock, eye damage, poisonous fumes, and overexposure to ultraviolet light.

### **TYPES OF WELDING**

#### **Arc Welding**

Arc welding is a process utilizing the concentrated heat of an electric arc to join metal by fusion of the parent metal and the addition of metal to joint usually provided by a consumable electrode. Either direct or alternating current may be used for the arc, depending upon the material to be welded and the electrode used.

#### **Gas Welding**

It is a metal joining process in which the ends of pieces to be joined are heated at their interface by producing coalescence with one or more gas flames (such as oxygen and acetylene), with or without the use of a filler metal.

#### **Welding Safety**

Welding hazards pose an unusual combination of safety and health risks. By its nature, welding produces fumes and noise, gives off radiation, involves electricity or gases, and has the potential for burns, shock, fire, and explosions.

Some hazards are common to both electric arc and oxygen-fuel gas welding. If you work with or near a welding operation, the following general precautions should help you to work more safely.

- Weld only in designated areas.
- Only operate welding equipment you have been trained to use.
- Know what the substance is that's being welded and any coating on it.
- Wear protective clothing to cover all exposed areas of the body for protection sparks, hotspatter, and radiation.
- Protective clothing should be dry and free of holes, grease, oil, and other substances which may burn.
- Wear flameproof gauntlet gloves, a leather or asbestos apron, and high-top shoes to provide good protection against sparks and spatter.
-

- Wear specifically designed, leak-proof helmets equipped with filter plates to protect against ultraviolet, infrared, and visible radiation.
- Never look at a flash, even for an instant.
- Keep your head away from the plume by staying back and to the side of the work.
- Use your helmet and head position to minimize fume inhalation in your breathing zone.
- Make sure there is good local exhaust ventilation to keep the air in your breathing zone clear.
- Don't weld in a confined space without adequate ventilation and a NIOSH-approved respirator.
- Don't weld in wet areas, wear wet or damp clothing or weld with wet hands.
- Don't weld on containers which have held combustible materials or on drums, barrels or tanks until proper safety precautions have been taken to prevent explosions.
- If others are working in the area be sure they are warned and protected against arcs, fumes, sparks, and other welding hazards.
- Don't coil the electrode cable around your body.
- Ground both the frame of the welding equipment and metal being welded.
- Check for leaks in gas hoses using an inert gas.
- Check area around you before welding to be sure no flammable material or degreasing solvents are in the welding area.
- Keep a fire watch in the area during and after welding to be sure there are no smoldering materials, hot slag or live sparks which could start a fire.
- Locate the nearest fire extinguisher before welding.
- Deposit all scraps and electrode butts in proper waste container to avoid fire and toxic fumes.



## **Types of arc welding**

Different types of arc welding are.

1. Carbon arc welding
2. Metal arc welding
3. Metal inert gas welding
4. Submerged arc welding
5. Plasma arc welding etc.

## **Electric Arc Welding.**

Electric arc welding is the most widely used of the various arc welding processes. Welding is performed with the heat of an electric arc that is maintained between the end of a coated metal electrode and the work piece (See Figure 1). The heat produced by the arc melts the base metal, the electrode core rod, and the coating. As the molten metal droplets are transferred across the arc and into the molten weld puddle, they are shielded from the atmosphere by the gases produced from the decomposition of the flux coating. The molten slag floats to the top of the weld puddle where it protects the weld metal from the atmosphere during solidification. Other functions of the coating are to provide arc stability and control bead shape. More information on coating functions will be covered in subsequent lessons.

**Welding Power Sources:** Shielded metal arc welding may utilize either alternating current (AC) or direct current (DC), but in either case, the power source selected must be of the constant current type. This type of power source will deliver relatively constant amperage or welding current regardless of arc length variations by the operator the amperage determines the amount of heat at the arc and since it will remain relatively constant, the weld beads produced will be uniform in size and shape.

Whether to use an AC, DC, or AC/DC power source depends on the type of welding to be done and the electrodes used. The following factors should be considered: 1. **Electrode Selection** - Using a DC power source allows the use of a greater range of electrode types. While most of the electrodes are designed to be used on AC or DC, some will work properly only on DC.

**2. Metal Thickness** - DC power sources may be used for welding both heavy sections and light gauge work. Sheet metal is more easily welded with DC because it is easier to strike and maintain the DC arc at low currents.

**3. Distance from Work** - If the distance from the work to the power source is great, AC is the best choice since the voltage drop through the cables is lower than with DC. Even though welding cables are made of copper or aluminum (both good conductors), the resistance in the cables becomes greater as the cable length increases. In other words, a voltage reading taken between the electrode and the work will be somewhat lower than a reading taken at the output terminals of the power source. This is known as voltage drop.

**4. Welding Position** - Because DC may be operated at lower welding currents, it is more suitable for overhead and vertical welding than AC. AC can successfully be used for out-of-position work if proper electrodes are selected.

**5. Arc Blow** - When welding with DC, magnetic fields are set up throughout the weldment. In weldments that have varying thickness and protrusions, this magnetic field can affect the arc by making it stray or fluctuate in direction. This condition is especially troublesome when welding in corners. AC seldom causes this problem because of the rapidly reversing magnetic field produced.

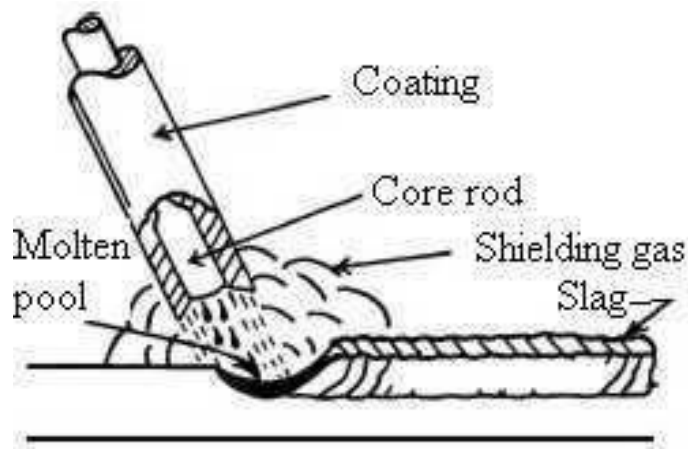

### **Oxy-Acetylene gas Welding**

Oxyacetylene welding, commonly referred to as gas welding, is a process which relies on combustion of oxygen and acetylene. When mixed together in correct proportions within a hand-held torch or blowpipe, a relatively hot flame is produced with a temperature of about 3,200°C. The chemical action of the oxyacetylene flame can be adjusted by changing the ratio of the volume of oxygen to acetylene.

Three distinct flame settings are used, neutral, oxidising and carburizing. Welding is generally carried out using the neutral flame setting which has equal quantities of oxygen and acetylene. The oxidising flame is obtained by increasing just the oxygen flow rate while the carburising flame is achieved by increasing acetylene flow in relation to oxygen flow. Because steel melts at a temperature above 1,500°C, the mixture of oxygen and acetylene is used as it is the only gas combination with enough heat to weld steel. However, other gases such as propane, hydrogen and coal gas can be used for joining lower melting point non-ferrous metals, and for brazing and silver soldering.

### **Equipment**

Oxyacetylene equipment is portable and easy to use. It comprises oxygen and acetylene gases stored under pressure in steel cylinders. The cylinders are fitted with regulators and flexible hoses which lead to the blowpipe. Specially designed safety devices such as flame traps are fitted between the hoses and the cylinder regulators. The flame trap prevents flames generated by a 'flashback' from reaching the cylinders; principal causes of flashbacks are the failure to purge the hoses and overheating of the blowpipe nozzle.

When welding, the operator must wear protective clothing and tinted coloured goggles. As the flame is less intense than an arc and very little UV is emitted, general-purpose tinted goggles provide sufficient protection.

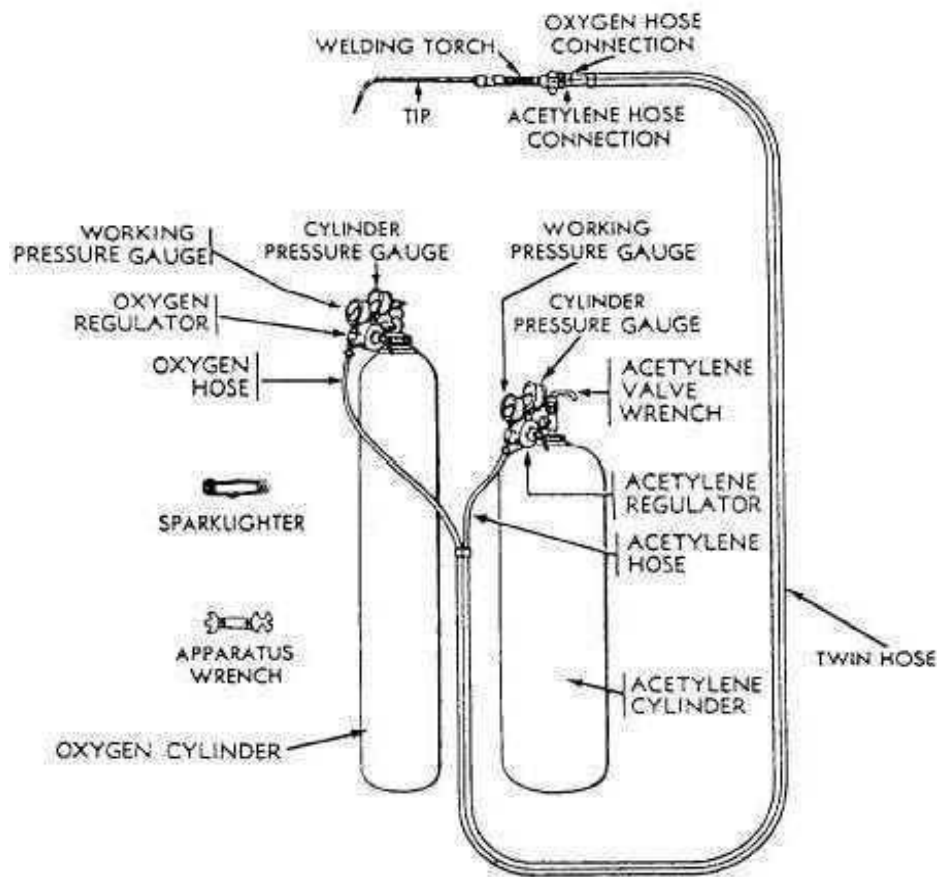

### Neutral Flame

As the supply of oxygen to the blowpipe is further increased; the flame contracts and the white cone become clearly defined, assuming a definite rounded shape. At this stage approximately equal quantities of acetylene and oxygen are being used and the combustion is complete, all the carbon supplied by the acetylene is being consumed and the maximum heat given out. The flame is now neutral, and this type of flame is the one most extensively used by the welder, who should make himself thoroughly familiar with its appearance and characteristics.

### Carburizing Flame

This is a flame in which an excess of acetylene is burning, i.e. combustion is incomplete and unconsumed carbon is present. When lighting the blowpipe the acetylene is turned on first and ignited, giving a very smoky yellow flame of abnormal size, showing two cones of flame in addition to an outer envelope; this is an exaggerated form of the carburizing flame, but gives out comparatively little heat and is of little use for welding.

### Oxidizing Flame

A further increase in the oxygen supply will produce an oxidizing flame in which there is more oxygen than is required for complete combustion. The inner cone will become shorter and sharper, the flame will turn a deeper purple colour and emit a characteristic slight "hiss", while the molten metal will be less fluid and tranquil during welding and excessive sparking will occur. An oxidizing flame is only used for special applications, and should never be used for welding.

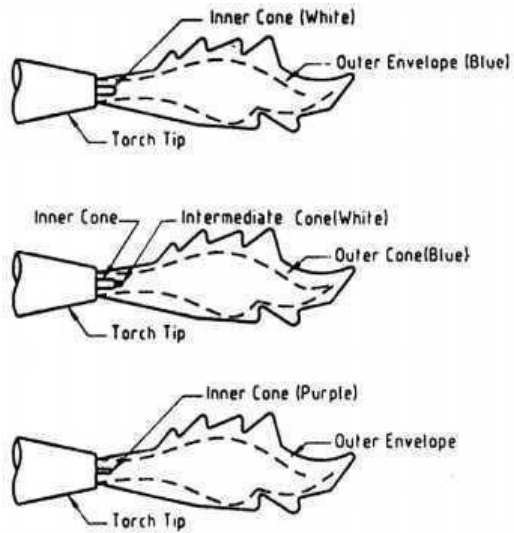

TYPES OF OXY-ACETYLENE FLAME

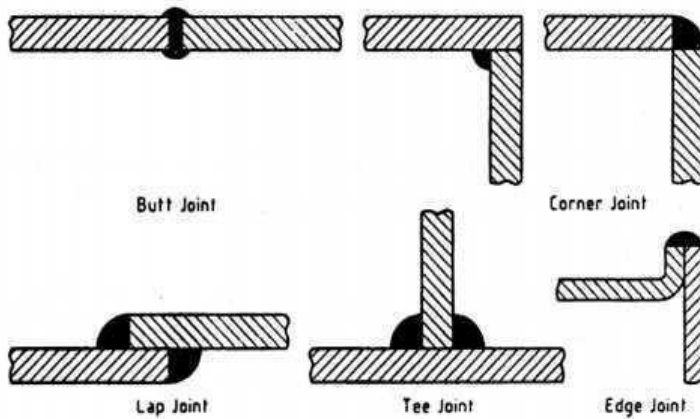

BASIC TYPES OF WELDED JOINTS

## Welding Tools and Safety Equipments

### Goggles

**Goggles** are forms of protective eyewear that usually enclose or protect the eye area in order to prevent particulates, infectious fluids, or chemicals from striking.

### Face Shield

Face shield is used to protect the eyes of the welder from the little sparks produced during welding. It is normally held in hand.

### Hand Gloves

Hand gloves are used to protect the hands from electrical shock, arc radiation and hot spatters.

### Tongs

Tongs are used to handle the hot metal – welding job while cleaning. They are also used to hold the metal for hammering.

### Chipping Hammer

Chipping hammer is a chisel shaped tool and is used to remove the slag from the weld bead.

**Wire brush**

A wire brush is made up of stiff steel wire embedded in a wooden piece. It removes small particles of slag from the weld bead after the chipping hammer has done its job.

**Welding Helmet**

Welding helmets are headgear used when performing certain types of welding to protect the eyes, face and neck from flash burn, ultraviolet light, sparks and heat. Welding helmets can also prevent retina burns, which can lead to a loss of vision.

**Ground Clamp**

It is connected to the end of the ground cable. It is normally clamped to the welding table or the job itself to complete the electric circuit.

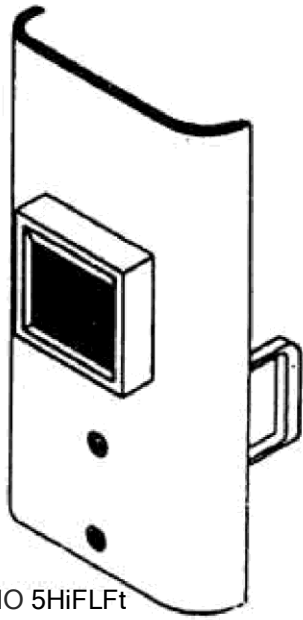

HAHO 5HiFLt

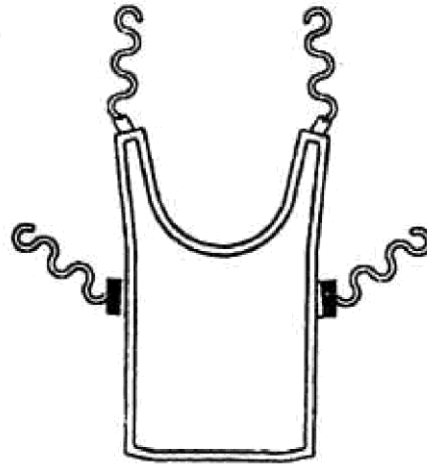

yWELDING APRQlq

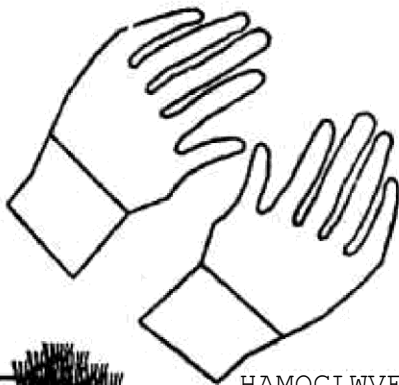

HAMOGlwVES

ELECYRODE HOLDER

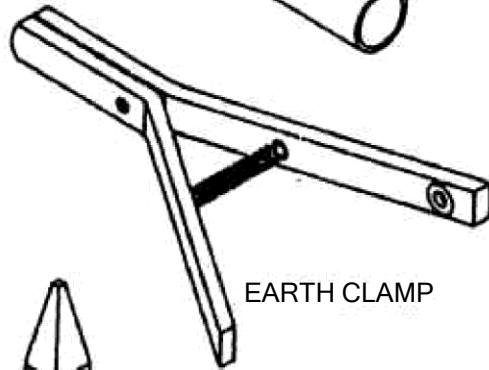
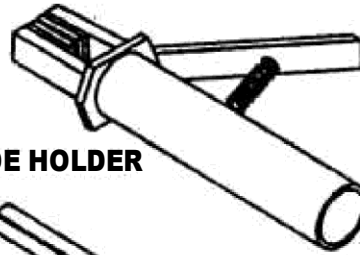

EARTH CLAMP

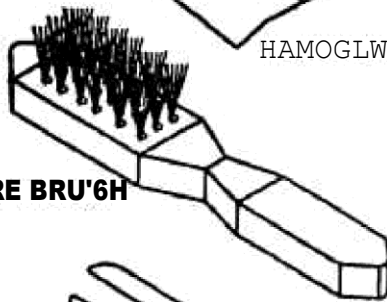

WIRE BRU'6H

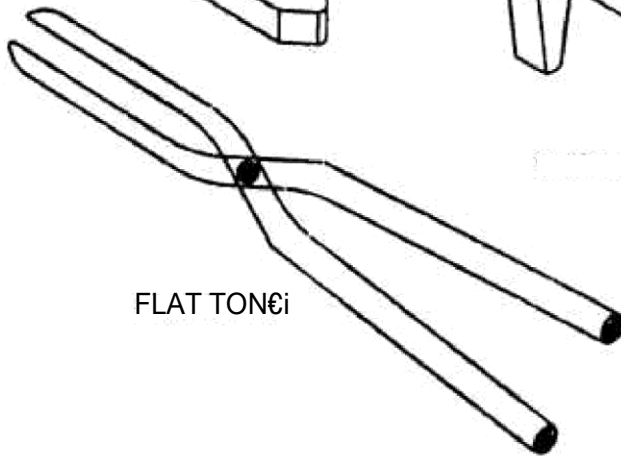
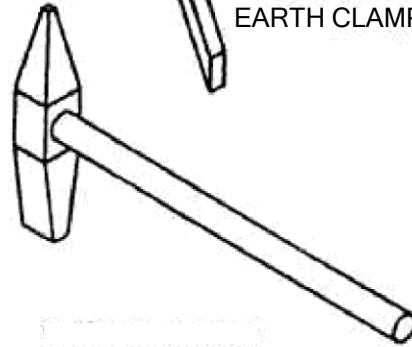

FLAT TON€i

## **Advantages of Arc Welding**

1. A big range of metals and their alloys can be welded.
2. Welding equipment is portable and the cost is fairly low.
3. Flux shielded manual metal arc welding is the simplest of all the arc welding processes.
4. The applications of the arc welding are innumerable, because of the availability of wide variety of electrodes.
5. Welding can be carried out in any position with highest weld quality.

## **Disadvantages of arc welding**

1. Because of the limited length of each electrode and brittle flux coating on it, mechanization is difficult.
2. In welding long joints, as one electrode finishes, the weld is to be progressed with the next electrode. A defect may occur at the place where welding is restarted with the new electrode.

## **Applications**

1. In reservoir tank, boiler and pressure vessel fabrications
2. Ship building
3. Pipes and pipe stock joining
4. Building and bridge construction
5. Automotive and air craft industry.

## **Types of Joints**

1. Butt joint
2. Lap joint
3. Edge joint
4. T – Joint
5. Corner joint

### **1. Butt joint**

It is used to join the ends or edges of plates lying in the same plane. Plates having thickness less than 5mm do not require edge preparation but plates having thickness more than 5mm require edge preparation on both sides.

### **2. Lap joint**

It is used to join two overlapping pieces so that the edges of each piece are welded to the surface of the other. It is used on plates less than 3mm thickness. Common types are single lap and double lap joint. Edge preparation is not required for these joints.

### **3. Edge joint**

It is used to weld two parallel plates. This is economical for joining thin plates up to 6mm. This joint is often used in sheet metal work. It is suitable for severe loading.

### **4. T – Joint**

It is used to weld two perpendicular plates. This is economical for joining thin plates up to 3mm. This joint is often used in structures.

### **5. Corner joint**

It is used to join the edges of two pieces whose surfaces are approximately at right angles to each other. It is common in the construction of boxes, tanks, frames and other similar items.

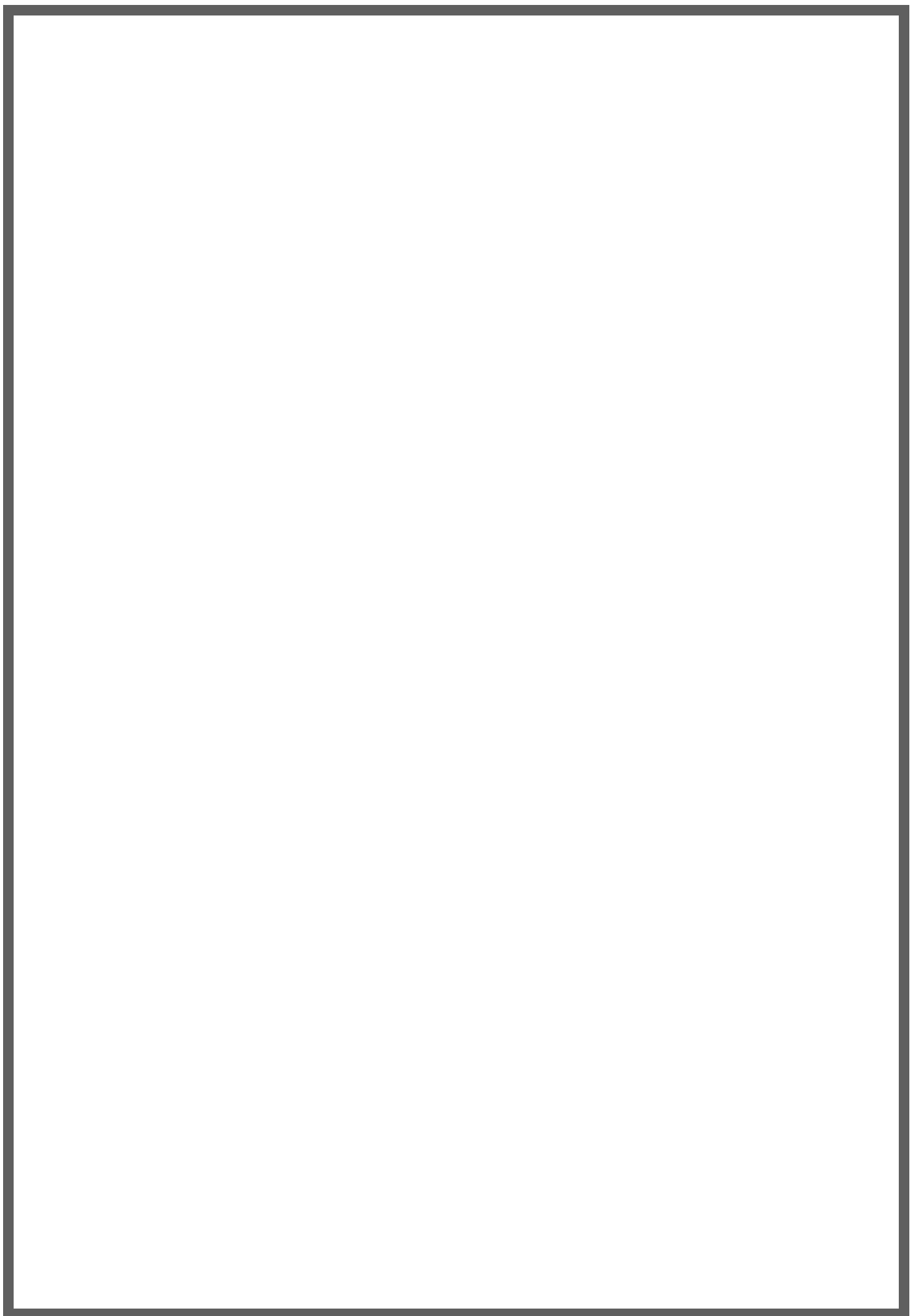



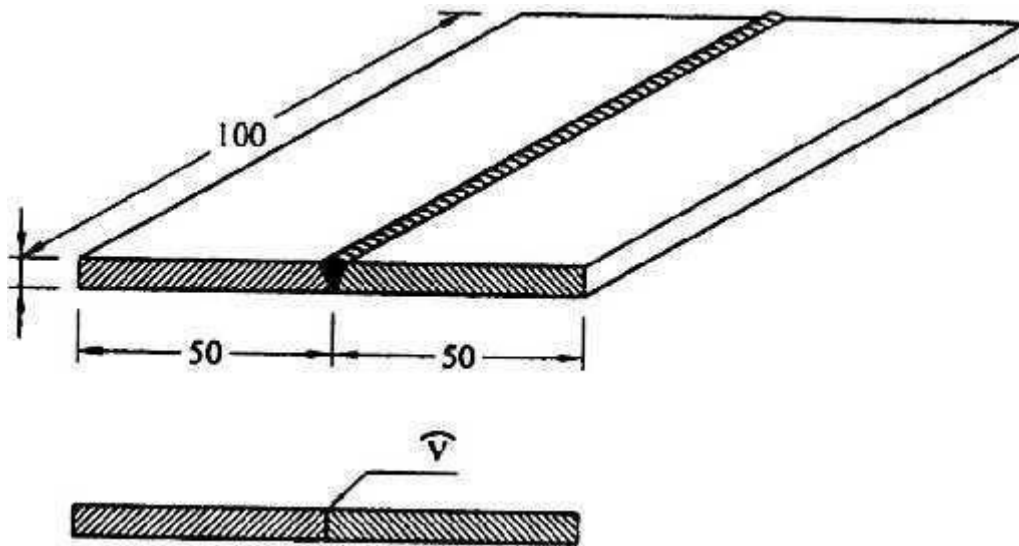

All Dimensions are in mm.

<b>BUTT JOINT</b>	
<b>DATE:</b>	<b>EX.NO.1</b>

**Aim:**

To make a butt joint on the given work pieces using arc welding.

**Apparatus required:**

Welding machine

**Tools Required:**

Work pieces, Welding electrodes, Welding machine, Tongs, Wire brush, chipping hammer, Gloves and Goggles.

**Procedure:**

1. The given work pieces are cleaned with the wire brush to remove the rust, scale and other impurities.
2. Edges are prepared suitably to the given dimension and positioned for the butt joint.
3. Depending upon the thickness of the parent metal, the amperage and correct voltage is selected.
4. With goggles covering the eyes and gloves on hands, an arc is struck on the work piece and tacks are made at the extreme ends.
5. Welding process is progressed along the seam at a constant speed and keeping uniform distance between the electrode and the work piece.
6. Using chipping hammer the flux in the form of slag is chipped off and then cleaned.
7. After welding, the work pieces should be handles only using the tongs.

**Result:**

Thus the required butt joint is obtained as per the given dimensions.

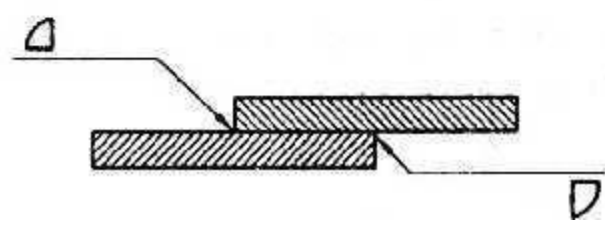
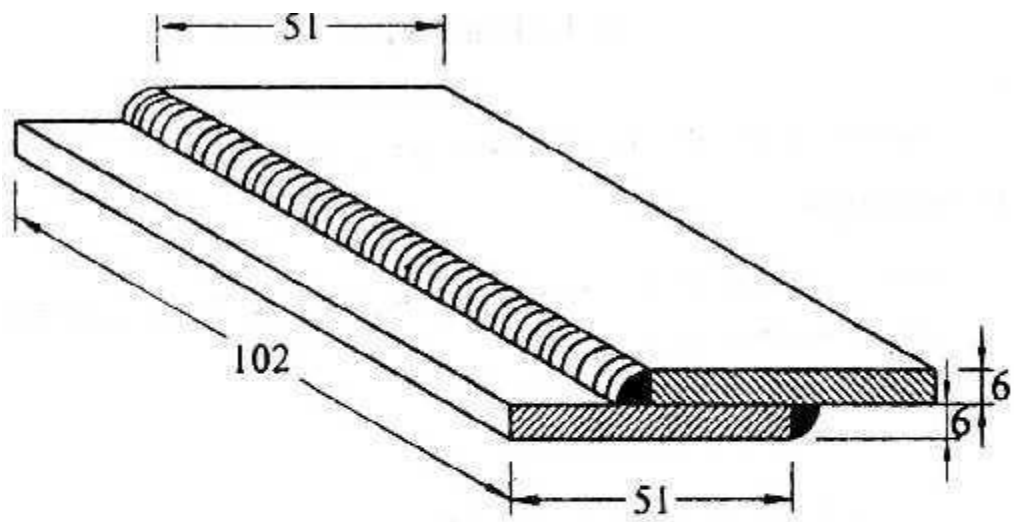

All Dimensions are in mm.

<b>LAP JOINT</b>	
<b>DATE:</b>	<b>EX.NO.2</b>

To

**Aim:**

make a lap joint on the given work pieces using arc welding.

**Apparatus required:**

Welding machine

**Tools Required:**

Work pieces, Welding electrodes, Welding machine, Tongs, Wire brush, chipping hammer, Gloves and Goggles.

**Procedure:**

1. The given work pieces are cleaned with the wire brush to remove the rust, scale and other impurities.
2. Edges are prepared suitably to the given dimension and positioned one over another for the lap joint.
3. Depending upon the thickness of the parent metal, the amperage and correct voltage is selected.
4. With goggles covering the eyes and gloves on hands, an arc is struck on the work piece and tacks are made at the extreme ends.
5. Welding process is progressed along the seam at a constant speed and keeping uniform distance between the electrode and the work piece.
6. Using chipping hammer the flux in the form of slag is chipped off and then cleaned.
7. After welding, the work pieces should be handles only using the tongs.

**Result:**

Thus the required lap joint is obtained as per the given dimensions.

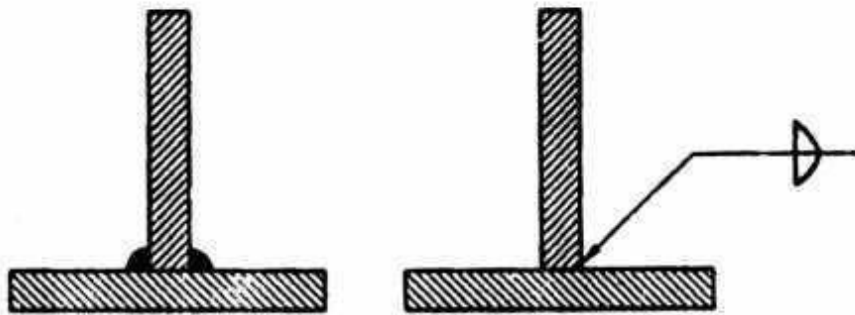
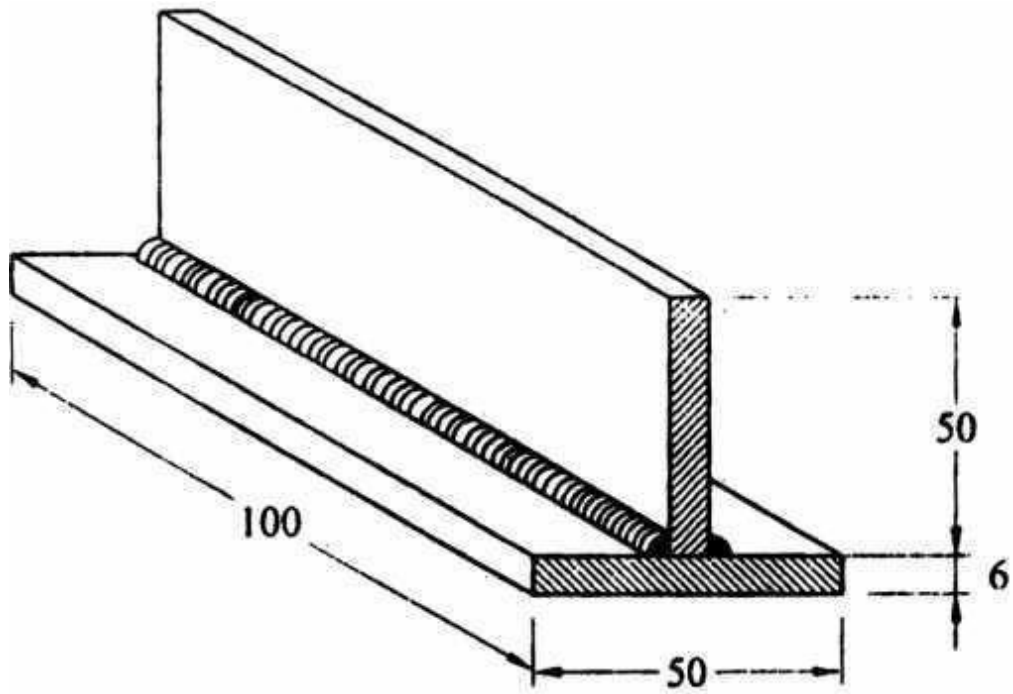

**Welded Joint Representation**

All Dimensions are in mm.

<b>T JOINT</b>	
<b>DATE:</b>	<b>EX.NO.3</b>

**Aim:**

To make a T - joint on the given work pieces using arc welding.

**Apparatus required:**

Welding machine

**Tools Required:**

Work pieces, Welding electrodes, Welding machine, Tongs, Wire brush, chipping hammer, Gloves and Goggles.

**Procedure:**

1. The given work pieces are cleaned with the wire brush to remove the rust, scale and other impurities.
2. Edges are prepared suitably to the given dimension and positioned at right angles for the tee joint.
3. Depending upon the thickness of the parent metal, the amperage and correct voltage is selected.
4. With goggles covering the eyes and gloves on hands, an arc is struck on the work piece and tacks are made at the extreme ends.
5. Welding process is progressed along the seam at a constant speed and keeping uniform distance between the electrode and the work piece.
6. Using chipping hammer the flux in the form of slag is chipped off and then cleaned.
7. After welding, the work pieces should be handles only using the tongs.

**Result:**

Thus the required T - joint is obtained as per the given dimensions.

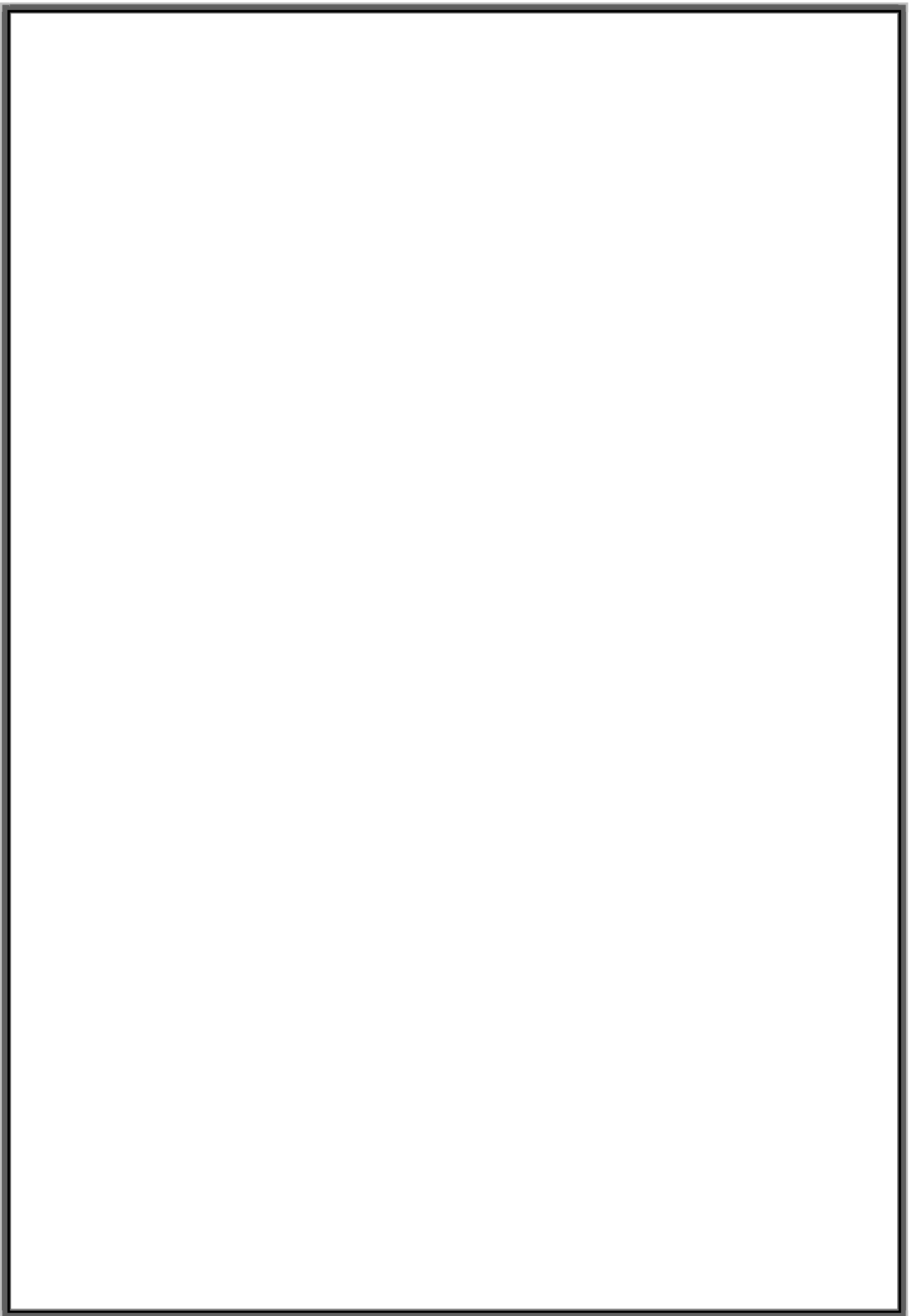

**LATHE**



## **LATHE**

The lathe is used for producing cylindrical work. The work piece is rotated while the cutting tool movement is controlled by the machine. The lathe is primarily used for cylindrical work. The lathe may also be used for: Boring, drilling, tapping, turning, facing, threading, polishing, grooving, knurling etc.

The purpose of a lathe is to rotate a part against a tool whose position it controls. It is useful for fabricating parts and/or features that have a circular cross section. The spindle is the part of the lathe that rotates. Various work holding attachments such as three jaw chucks, collets, and centers can be held in the spindle. The spindle is driven by an electric motor through a system of belt drives and/or gear trains. Spindle speed is controlled by varying the geometry of the drive train.

The tailstock can be used to support the end of the work piece with a center, or to hold tools for drilling, reaming, threading, or cutting tapers. It can be adjusted in position along the ways to accommodate different length work pieces. The ram can be fed along the axis of rotation with the tailstock hand wheel.

The carriage controls and supports the cutting tool. It consists of: A saddle that mates with and slides along the ways, an apron that controls the feed mechanisms, a cross slide that controls transverse motion of the tool (toward or away from the operator), a tool compound that adjusts to permit angular tool movement and a tool post T-slot that holds the tool post.

### **Feed, Speed, And Depth of Cut**

Cutting speed is defined as the speed at which the work moves with respect to the tool. Feed rate is defined as the distance the tool travels during one revolution of the part. Cutting speed and feed determines the surface finish, power requirements, and material removal rate. The primary factor in choosing feed and speed is the material to be cut. However, one should also consider material of the tool, rigidity of the work piece, size and condition of the lathe, and depth of cut. To calculate the proper spindle speed, divide the desired cutting speed by the circumference of the work.

## Parts of Lathe

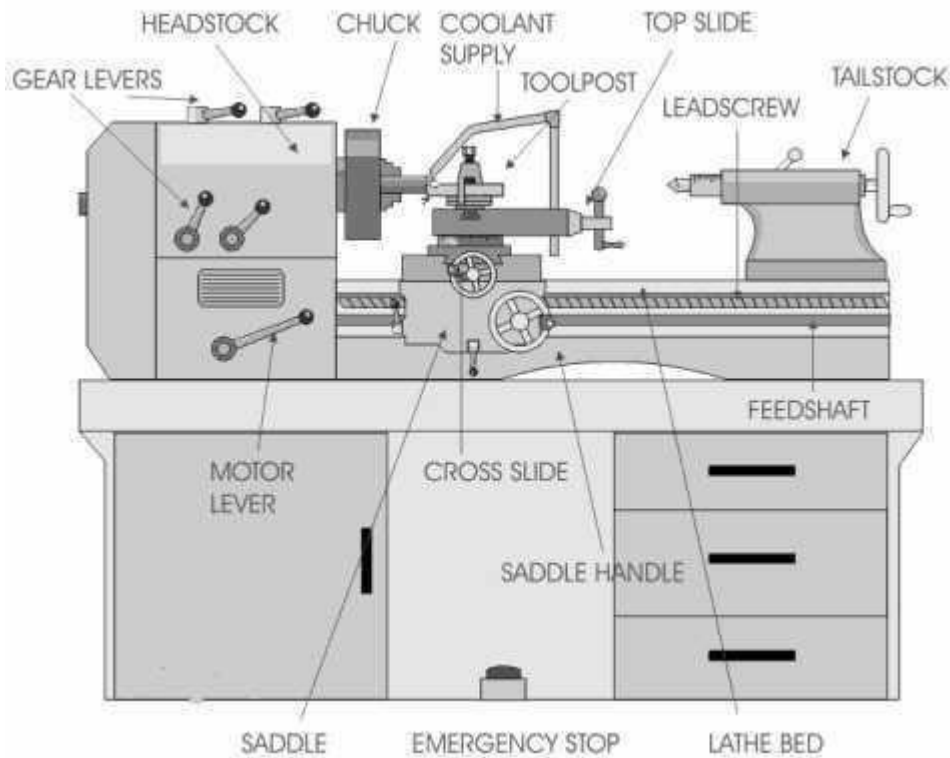

### Head Stock

The headstock houses the main spindle, speed change mechanism, and change gears. The headstock is required to be made as robust as possible due to the cutting forces involved, which can distort a lightly built housing, and induce harmonic vibrations that will transfer through to the work piece, reducing the quality of the finished work piece.

### Bed

The bed is a robust base that connects to the headstock and permits the carriage and tailstock to be aligned parallel with the axis of the spindle. This is facilitated by hardened and ground ways which restrain the carriage and tailstock in a set track. The carriage travels by means of a rack and pinion system, lead screw of accurate pitch, or feed screw.

### Feed and lead screws

The feed screw is a long driveshaft that allows a series of gears to drive the carriage mechanisms. These gears are located in the apron of the carriage. Both the feed screw and lead screw are driven by either the change gears or an intermediate gearbox known as a quick change gearbox or Norton gearbox. These intermediate gears allow the correct ratio and direction to be set for cutting threads or worm gears. Tumbler gears are provided between the spindle and gear train that enables the gear train of the correct ratio and direction to be introduced. This provides a constant relationship

between the number of turns the spindle makes, to the number of turns the lead screw makes. This ratio allows screw threads to be cut on the work piece without the aid of a die.

### **Carriage**

In its simplest form the carriage holds the tool bit and moves it longitudinally (turning) or perpendicularly (facing) under the control of the operator. The operator moves the carriage manually via the hand wheel or automatically by engaging the feed screw with the carriage feed mechanism, this provides some relief for the operator as the movement of the carriage becomes power assisted. The hand wheels on the carriage and its related slides are usually calibrated both for ease of use and to assist in making reproducible cuts.

### **Cross-slide**

The cross-slide stands atop the carriage and has a lead screw that travels perpendicular to the main spindle axis, this permit facing operations to be performed. This lead screw can be engaged with the feed screw (mentioned previously) to provide automated movement to the cross-slide; only one direction can be engaged at a time as an interlock mechanism will shut out the second gear train.

### **Compound rest**

The compound rest is the part of the machine where the tool post is mounted. It provides a smaller amount of movement along its axis via another lead screw. The compound rest axis can be adjusted independently of the carriage or cross-slide. It is utilized when turning tapers, when screw cutting or to obtain finer feeds than the lead screw normally permits.

### **Tool post**

The tool bit is mounted in the tool post which may be of the American lantern style, traditional 4 sided square styles, or in a quick change style. The advantage of a quick change set-up is to allow an unlimited number of tools to be used (up to the number of holders available) rather than being limited to 1 tool with the lantern style, or 3 to 4 tools with the 4 sided type.

### **Tail Stock**

The tailstock is a tool holder directly mounted on the spindle axis, opposite the headstock. The spindle does not rotate but does travel longitudinally under the action of a lead screw and hand wheel. The spindle includes a taper to hold drill bits, centers and other tooling. The tailstock can be positioned along the bed and clamped in position as required. There is also provision to offset the tailstock from the spindles axis; this is useful for turning small tapers.

## **Lathe Operations**

### **Turning**

Turning is the machining operation that produces cylindrical parts. In its basic form, it can be defined as the machining of an external surface:

- with the work piece rotating,
- with a single-point cutting tool, and
- with the cutting tool feeding parallel to the axis of the work piece and at a distance that will remove the outer surface of the work.

Taper turning is practically the same, except that the cutter path is at an angle to the work axis. Similarly, in contour turning, the distance of the cutter from the work axis is varied to produce the desired shape

### **Facing**

Facing is the producing of a flat surface as the result of a tool's being fed across the end of the rotating work piece. Unless the work is held on a mandrel, if both ends of the work are to be faced, it must be turned end for end after the first end is completed and the facing operation repeated. The cutting speed should be determined from the largest diameter of the surface to be faced. Facing may be done either from the outside inward or from the center outward. In either case, the point of the tool must be set exactly at the height of the center of rotation.

### **Parting**

Parting is the operation by which one section of a work piece is severed from the remainder by means of a cutoff tool. Because cutting tools are quite thin and must have considerable overhang, this process is less accurate and more difficult. The tool should be set exactly at the height of the axis of rotation, be kept sharp, have proper clearance angles, and be fed into the work piece at a proper and uniform feed rate.

### **Drilling**

A lathe can also be used to drill holes accurately concentric with the centerline of a cylindrical part. First, install a drill chuck into the tail stock. Make certain that the tang on the back of the drill chuck seats properly in the tail stock. Withdraw the jaws of the chuck and tap the chuck in place with a soft hammer.

Move the saddle forward to make room for the tailstock. Move the tailstock into position, and lock the bit in place.

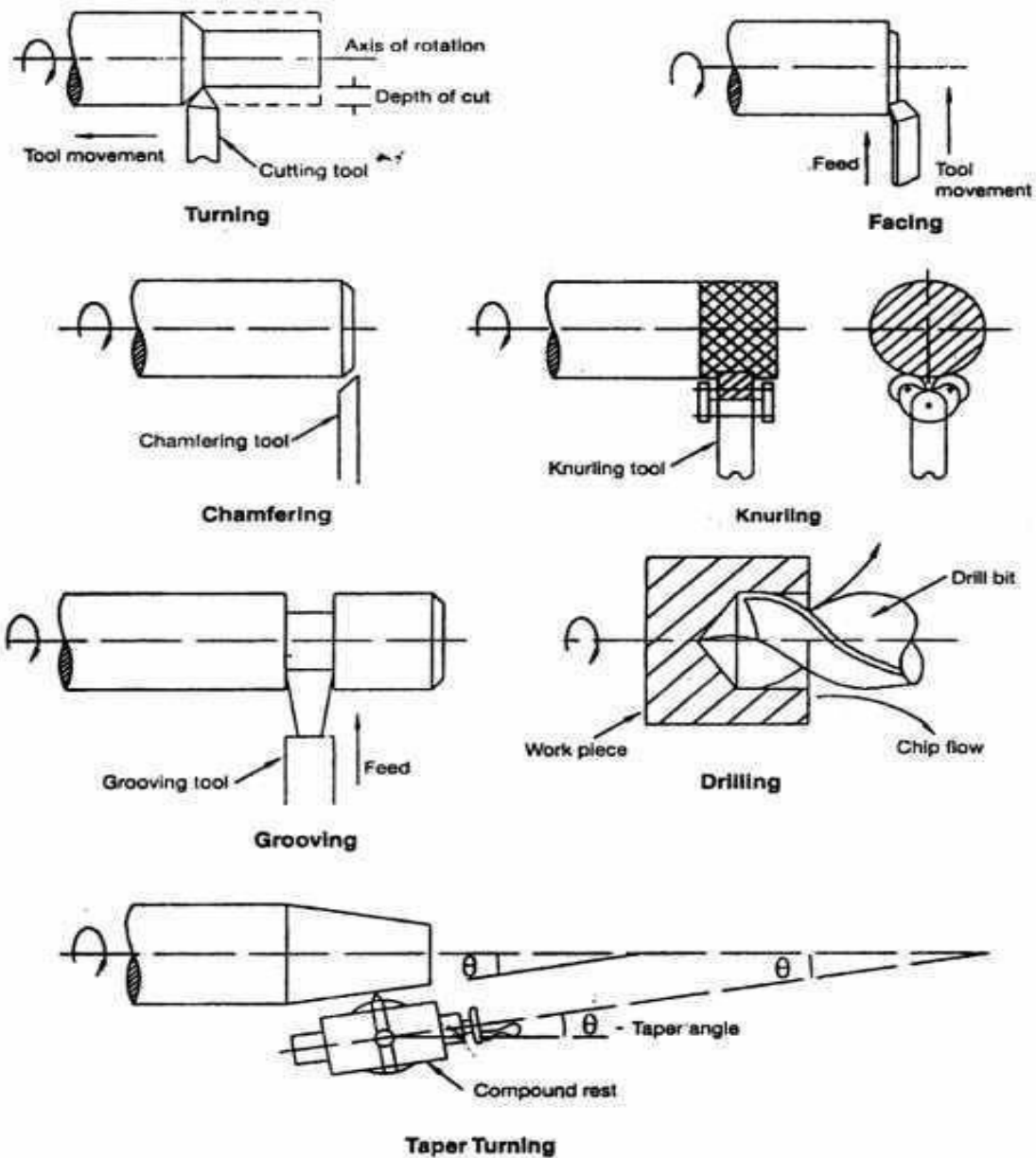

Before starting the machine, turn the spindle by hand. Just move the saddle forward, so it could interfere with the rotation of the lathe chuck. Always use a center drill to start the hole. .

### Boring

Boring is an operation in which a hole is enlarged with a single point cutting tool. A boring bar is used to support the cutting tool as it extends into the hole. Because of the extension of the boring bar, the tool is supported less rigidly and is more likely to chatter. This can be corrected by using slower spindle speeds or by grinding a smaller radius on the nose of the tool.

### Single Point Thread Turning

External threads can be cut with a die and internal threads can be cut with a tap. But for some diameters, no die or tap is available. In these cases, threads can be cut on a lathe. A special cutting tool should be used, typically with a 60 degree nose angle. To form threads with a specified number of threads per inch, the spindle is mechanically coupled to the carriage lead screw. Procedures vary for different machines

# Drilling Machine

The machine which performs the drilling operation is known as drilling machine. There are two types of machine drill, the bench drill and the pillar drill. The bench drill is used for drilling holes through materials including a range of woods, plastics and metals. It is normally bolted to a bench so that it cannot be pushed over and that larger pieces of material can be drilled safely.

The larger version of the machine drill is called the pillar drill. This has a long column which stands on the floor. This can do exactly the same work as the bench drill but because of its larger size it is capable of being used to drill larger pieces of materials and produce larger holes.

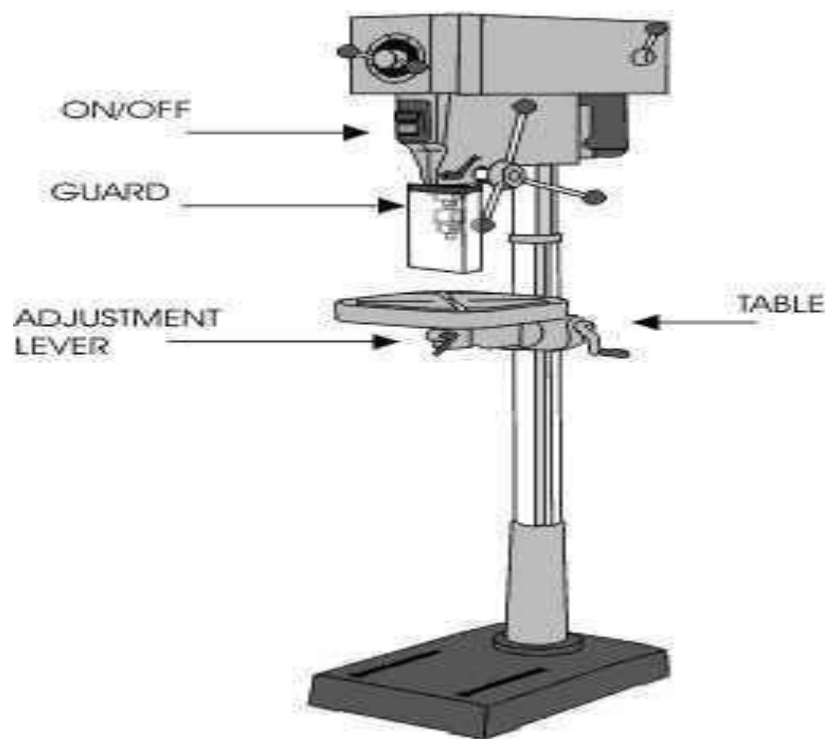

## **SAFETY MEASURES**

1. Always use the guard.
2. Wear goggles when drilling materials.
3. Clamp the materials down or use a machine vice.
4. Never hold materials by hand while drilling.
5. Always allow the 'chippings' to clear the drill by drilling a small amount at a time.
6. Follow all teacher instructions carefully.

## **TYPES OF DRILLING MACHINE**

1. Portable drilling machine
2. Sensitive drilling machine
3. Upright drilling machine
4. Radial drilling machine
5. Gang drilling machine
6. Multi spindle drilling machine

### **Bench Drill**

The bench drill is a smaller version of the pillar drill. This type of machine drill is used for drilling light weight pieces of material. The work piece is held safely in a hand vice which is held in the hand. NEVER hold work directly in the hand when drilling. The on and off buttons are found on the left hand side of the machine and the handle controlling the movement of the drill on the right. Most bench drills will also have a foot switch for turning off the drill. The hand vice is one safe way of holding material whilst drilling. It has two jaws that are closed by turning a wing nut.

### **Drilling Operations**

#### **1. Drilling**

It is the operation by which circular holes can be produced by rotating a tool called drill bit against the work piece. Using centre punch the centre of the hole is marked before drilling. The hole produced by drilling will be rough and of less accuracy.

#### **2. Reaming**

It is the operation of finishing and sizing the already drilled hole. The tool used is called reamer. It removes very little amount of metal to finish the hole.

#### **3. Boring**

The operation to enlarge the drilled hole is called boring. For boring, the cutter is held in a boring bar and is fixed to the spindle. It gives good surface finish.

#### **4. Counter boring**

To seat the heads of socket, screw and studs, a drilled hole is enlarged to a given depth. This operation is called counter boring.

#### **5. Counter sinking**

The operation of machining a conical enlargement at the top of a drilled hole is called counter sinking.

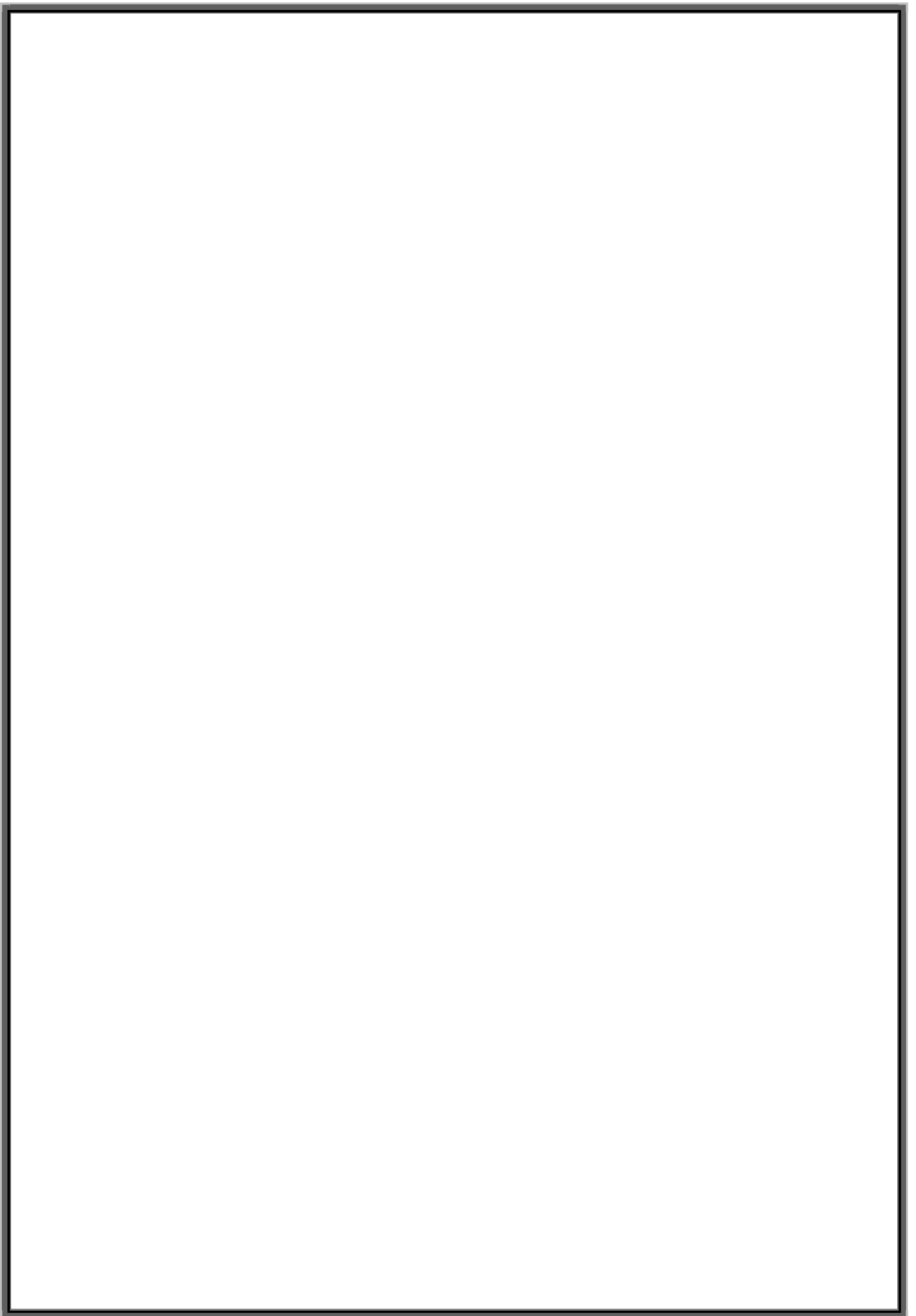



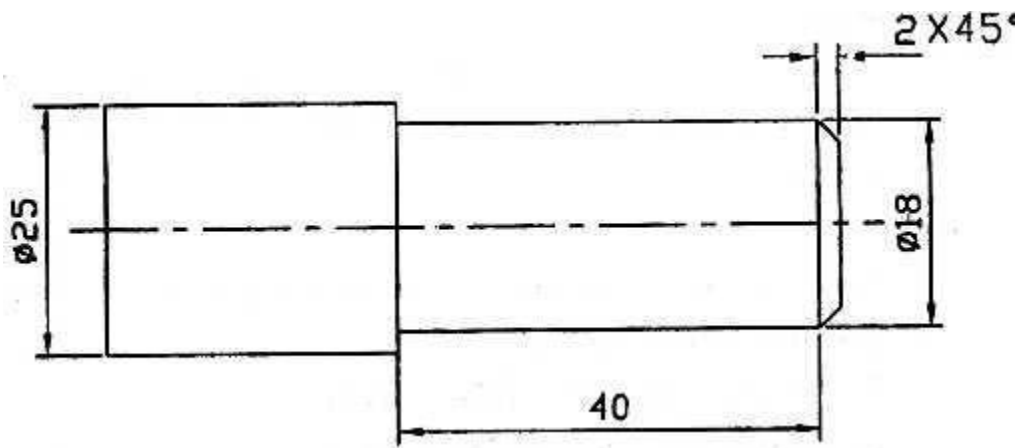

All dimensions are in mm

## TURNING, FACING AND CHAMFERING

**DATE:**

**EX.NO.4**

### **Aim**

To perform turning, facing and chamfering on a cylindrical work piece

### **Tools/Apparatus Required**

1. Lathe
2. Three jaw chuck
3. Chuck key
4. Single point cutting tool
5. Vernier caliper

### **Procedure**

1. Loosen the jaws in the chuck using chuck key to position the work piece and then tighten the jaws.
2. Fix the single point cutting tool in the tool post
3. Switch on the lathe, move the carriage near the work piece and give a small cross feed. Move the carriage slowly to the required length
4. Bring the carriage to the original position, give a small cross feed and repeat the steps until the required diameter is obtained. At the end give very small feed to get smooth surface.
5. For facing operation, the cutting tool is tilted by  $30^\circ$  and move the carriage to make the tool touch the end surface of the work piece.
6. Give small feed in longitudinal direction and then move the tool inwards using cross slide.
7. For chamfering operation, set the cross slide to  $45^\circ$ , give small feed in longitudinal direction and then move the tool using cross slide.
8. Check the dimensions regularly using vernier caliper.

### **Result**

Thus the turning, facing and chamfering operations are carried out on the given work piece

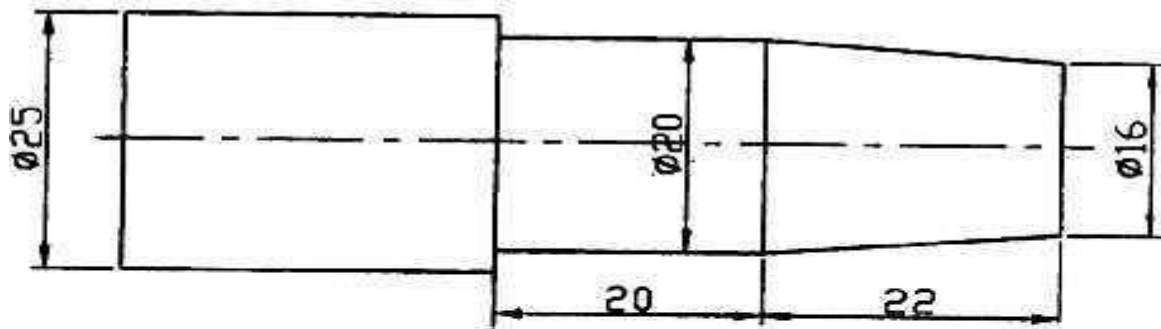

$$\text{Taper angle } \tan \theta = \frac{D - d}{2L}$$

D – Larger diameter of taper

d – Smaller diameter of taper

L – Tapered length

All dimensions are in mm

<b>TAPER TURNING</b>	
<b>DATE:</b>	<b>EX.NO.5</b>

**Aim**

To perform taper turning operation on a cylindrical work piece

**Tools/Apparatus Required**

1. Lathe
2. Three jaw chuck
3. Chuck key
4. Single point cutting tool
5. Vernier caliper

**Procedure**

1. Loosen the jaws in the chuck using chuck key to position the work piece and then tighten the jaws.
2. Fix the single point cutting tool in the tool post
3. Switch on the lathe, move the carriage near the work piece and give a small cross feed. Move the carriage slowly to the required length
4. Bring the carriage to the original position, give a small cross feed and repeat the steps until the required diameter is obtained. At the end give very small feed to get smooth surface.
5. To produce a taper, rotate and set the cross slide to the required angle.
6. Give a small feed and then move the tool using the cross slide. Repeat the steps to complete the taper.
7. Check the dimensions regularly using vernier caliper.

**Result**

Thus the taper turning operation is carried out on the given work piece

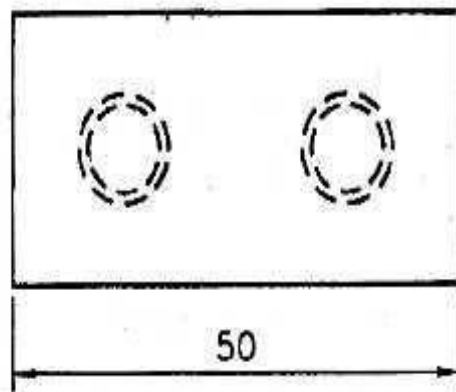
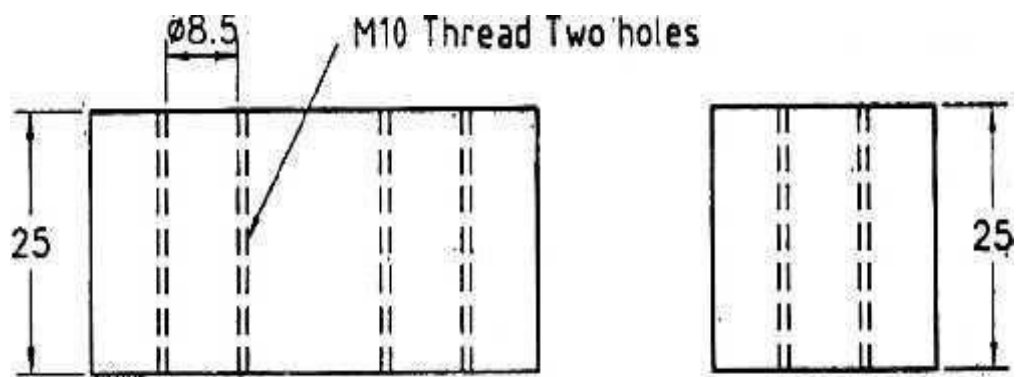

Dimensions After Machining

All dimensions are in mm

<b>DRILLING AND TAPPING</b>	
<b>DATE:</b>	<b>EX.NO.4</b>

**Aim:**

To make an internal thread on a given work piece as per the required dimensions using drilling machine and tapping tool.

**Tools/Apparatus Required:**

- |                 |                     |
|-----------------|---------------------|
| 1. Machine vice | 2. Drilling machine |
| 3. Drill bit    | 4. Tapping tool     |
| 5. Dot punch    | 6. Hammer etc.      |

**Procedure:**

1. The dimensions of the given work piece is checked as per the requirement.
2. The work piece is clamped in the vice and any two surfaces are filed to get right angle.
3. Drill bit of required size is fitted in the drill chuck of the drilling machine.
4. The midpoint of the required hole is punched by using dot punch and hammer.
5. The punched dot is drilled by drilling machine.
6. After drilling the hole, they are tapped by using tap tool.
7. Finally the dimensions are checked.

**Result:**

Thus the given work piece is drilled and tapped to the required dimensions.

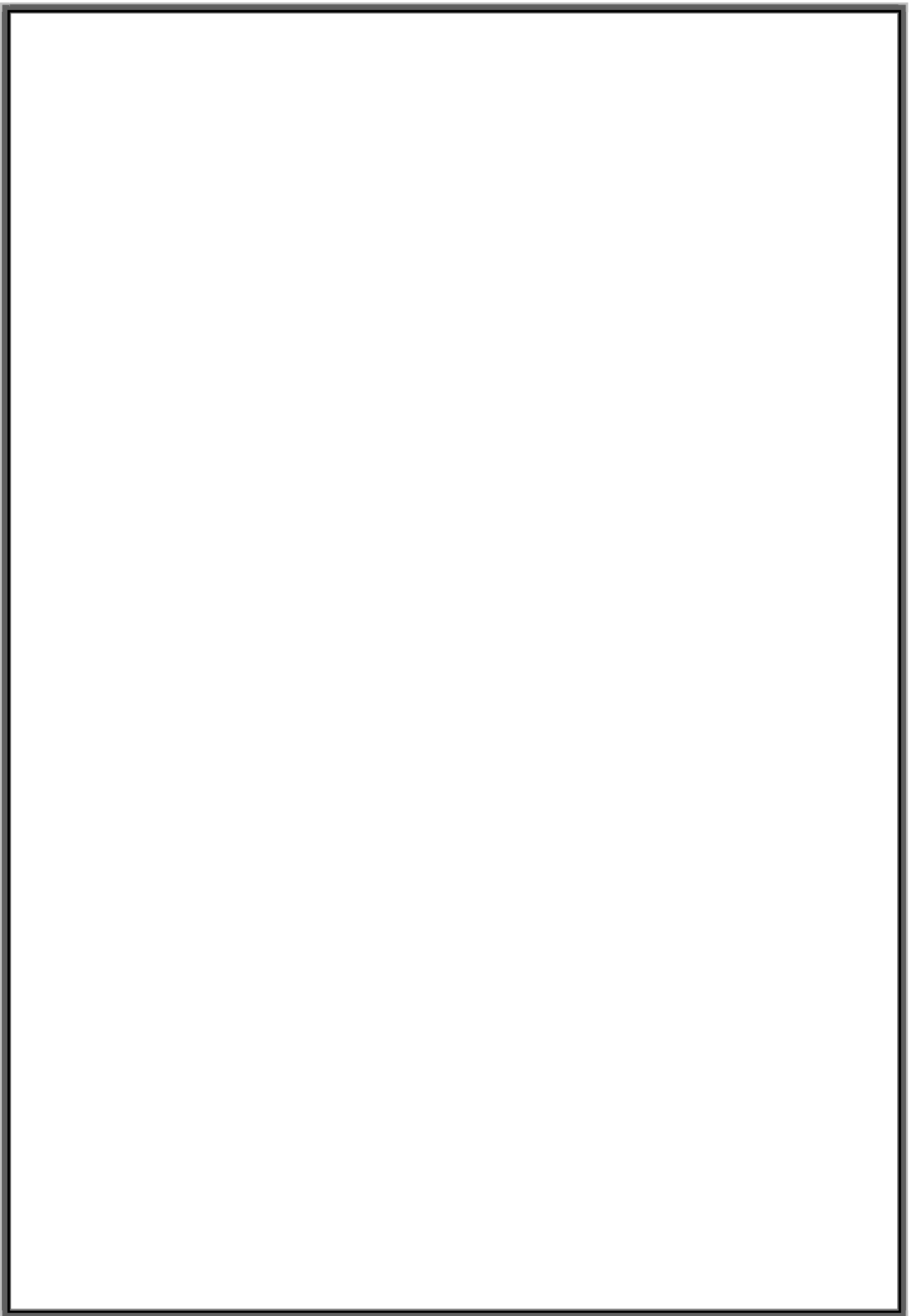

**FOUNDRY**

**&**

**SMITHY**



## FOUNDRY

A foundry is a factory which produces metal castings from either ferrous or non-ferrous alloys. Metals are turned into parts by melting the metal into a liquid, pouring the metal in a mold, and then removing the mold material or casting. The most common metal alloys produced are aluminum and cast iron. However, other metals, such as steel, magnesium, copper, tin, and zinc, can be processed.

A sand casting or a sand molded casting is a cast part produced by forming a mold from a sand mixture and pouring molten liquid metal into the cavity in the mold. The mold is then cooled until the metal has solidified. In the last stage the casting is separated from the mold. There are six steps in this process:

1. Place a pattern in sand to create a mold.
2. Incorporate a gating system.
3. Remove the pattern.
4. Fill the mold cavity with molten metal.
5. Allow the metal to cool.
6. Break away the sand mold and remove the casting.

There are two main types of sand used for molding. "Green sand" is a mixture of silica sand, clay, moisture and other additives. The "air set" method uses dry sand bonded to materials other than clay, using a fast curing adhesive. When these are used, they are collectively called "air set" sand castings to distinguish these from "green sand" castings. Two types of molding sand are natural bonded (bank sand) and synthetic (lake sand), which is generally preferred due to its more consistent composition.

## A METAL CASTING POURED IN A SAND MOLD

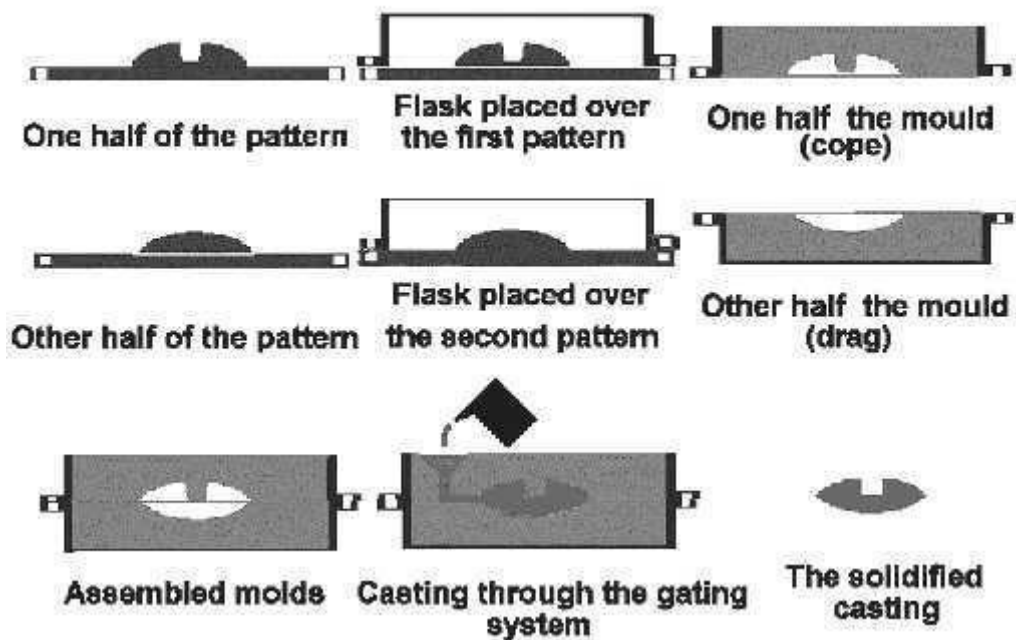

### Foundry hand tools

The hand tools commonly used in foundry are as follows.

#### 1. Shovel

It is used for mixing molding sand and for filling molding sand into the flask. A shovel is shown in fig.

#### 2. Riddle

Riddle is used for removing foreign materials from the moulding sand. It is shown in

#### 3. Rammer

This is used for packing or ramming the sand into the mould. Hand rammers are shown in fig. For large moulds, machine rammers are used.

#### 4. Trowel

A trowel is used for smoothening the surfaces of the mould. It is shown in fig.

#### 5. Sprue pin

It is a conical wooden pin, which is used while making the mould, for making an opening to pour the molten material into the cavity. A sprue pin is shown in fig.

#### 6. Vent rod

Vent rod is used for making small holes to permit gases to escape while the molten material is being poured. Fig. shows a vent rod.

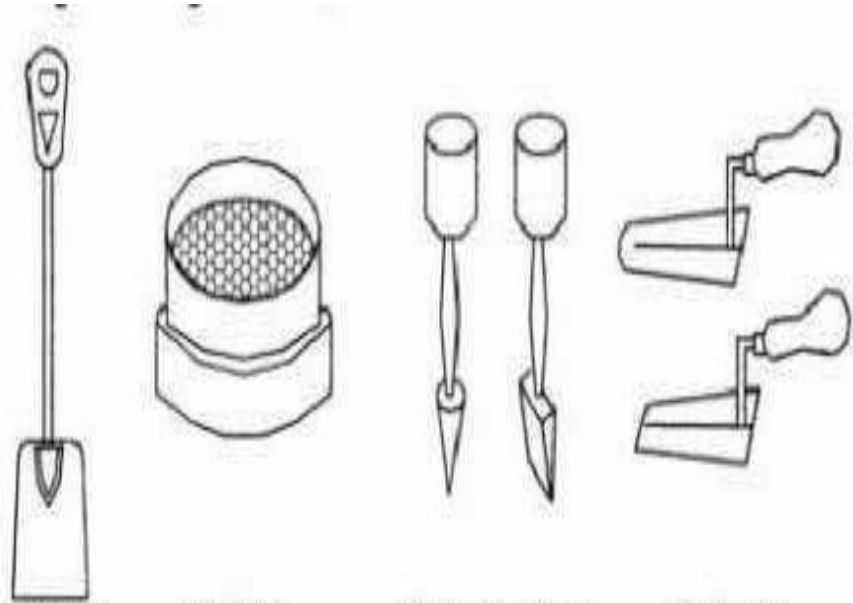

(a) Shovel

(b) Riddle

(c) Hand rammers

(d) Trowels

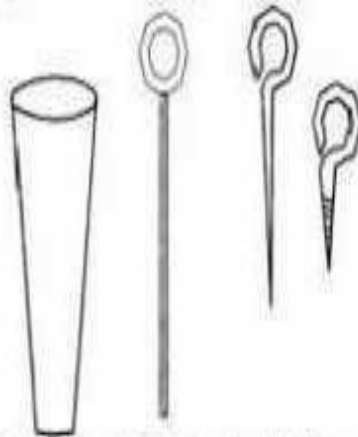

(e) Sprue pin

(f) Vent rod

(g) Draw spikes



(h) Moulding box

## **7. Draw spike**

This is used for drawing patterns from the sand. It has a loop at one end for pulling up the pattern from the mould. Draw spike is shown in fig.

## **8. Moulding boxes**

These are also known as moulding flasks. Moulding boxes are rigid frames made of iron or wood to hold the sand. The purpose of the flask is to impart necessary rigidity and strength to the rammed sand. Complete process of moulding is done in the moulding boxes. They are usually made in two parts, which are assembled with each other by pins on either side of the flasks. The top flask is called cope and the bottom flask is called drag. If the boxes are made in three sections then the middle one is called as cheek.

## **SMITHY**

Black smithy or forging is an ancient trade. It consists of heating a metal stock till it acquires sufficient plasticity, followed by hand forging, involving hammering, bending, pressing etc., till the desired shape is attained.

Hand forging is the term used when the process is carried out by hand tools. The hand forging process is generally employed for relatively small components. If power operated machines are used for the purpose, it is known as machine forging.

### **Advantages of forging**

1. Strength and toughness is high
2. Strength to weight ratio is high
3. Internal defects are eliminated.

A blacksmith is a person who creates objects from iron or steel by "forging" the metal; i.e., by using tools to hammer, bend, cut, and otherwise shape it in its non-liquid form. Usually the metal is heated until it glows red or orange as part of the forging process. Blacksmiths produce things like wrought iron gates, grills, railings, light fixtures, furniture, sculpture, tools, agricultural implements, decorative and religious items, cooking utensils etc.

### **Forging Operations**

There are five basic operations or techniques employed in forging: drawing, shrinking, bending, upsetting, and punching.

These operations generally employ hammer and anvil at a minimum, but smiths will also make use of other tools and techniques to accommodate odd-sized or repetitive jobs.

### **Drawing**

Drawing lengthens the metal by reducing one or both of the other two dimensions. As the depth is reduced, the width narrowed, or both the piece is lengthened or "drawn out". As an example of drawing, a smith making a wood chisel might flatten a square bar of steel, lengthening the metal, reducing its depth but keeping its width consistent.

### **Upsetting**

Upsetting is the process of making metal thicker in one dimension through shortening in the other. One form is by heating the end of a rod and then hammering on it as one would drive a nail: the rod gets shorter, and the hot part widens. An alternative to hammering on the hot end would be to place the hot end on the anvil and hammer on the cold end, or to drop the rod, hot end down, onto a piece of steel at floor level.

## **Shrinking**

Shrinking, while similar to upsetting, is essentially the opposite process as drawing. As the edge of a flat piece is curved,—as in the making of a bowl shape—the edge will become wavy as the material bunches up in a shorter radius. At this point the wavy portion is heated and the waves are gently pounded flat to conform to the desired shape.

## **Bending**

Heating steel to an orange heat allows bending. Bending can be done with the hammer over the horn or edge of the anvil, or by inserting the work into one of the holes in the top of the anvil and swinging the free end to one side. Bends can be dressed and tightened or widened by hammering them over the appropriately-shaped part of the anvil.

## **Punching**

Punching may be done to create a decorative pattern, or to make a hole. For example, in preparation for making a hammerhead, a smith would punch a hole in a heavy bar or rod for the hammer handle. Punching is not limited to depressions and holes. It also includes cutting, or slitting and drifting: these are done with a chisel.

## **Hand Forging Tools**

All a smith needs is something to heat the metal, [something to hold the hot metal with,] something to hit the metal on, and something to hit the metal with."

### **Anvil**

The anvil at its simplest is a large block of iron or steel. Over time this has been refined to provide a rounded horn to facilitate drawing and bending, a face for drawing and upsetting and bending, and one or more holes to hold special tools (swages or hardies) and facilitate punching. Often the flat surface of an anvil will be hardened steel, and the body made from tougher iron.

### **Tongs**

Tongs are used to hold the hot metal. They come in a range of shapes and sizes. Intriguingly, while tongs are needed for a great deal of blacksmithing, much work can be done by merely holding the cold end with one's bare hand: steel is a fairly poor conductor of heat, and orange-hot steel at one end would be cold to the touch a foot away or so.

### **Hammers**

Blacksmiths' hammers tend to have one face and a peen. The peen is typically either a ball or a blunt wedge (cross or straight peen depending on the orientation of the wedge to the handle) and is used when drawing.

## Swage block

Swages (hardies) and fullers are shaping tools. Swages are either stand alone tools or fit the "hardie hole" on the face of the anvil. The metal is shaped by being driven into the form of the swage. Opposite to the swage in some respects is the fuller which may take a number of shapes and is driven into the metal with a hammer. Swages and fullers are often paired to bring a piece of metal to shape in a single operation, essentially a set of dies. A fuller and swage pair might be spoon shaped, for example, the swage dished to form the bowl and the fuller the convex mirror of the swage. Together they will quickly stamp a spoon shape on the end of a bar.

### SWAGE BLOCK

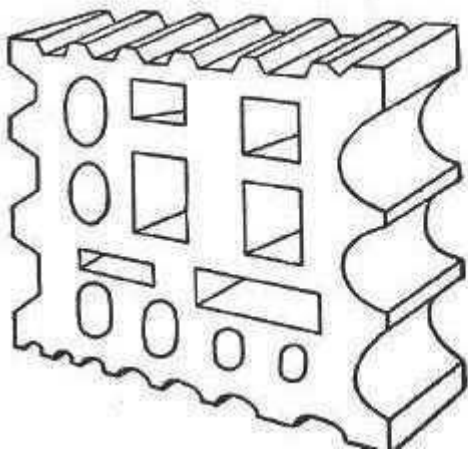

### FULLER

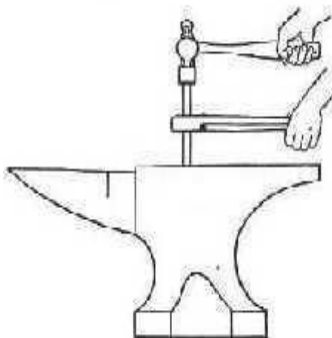
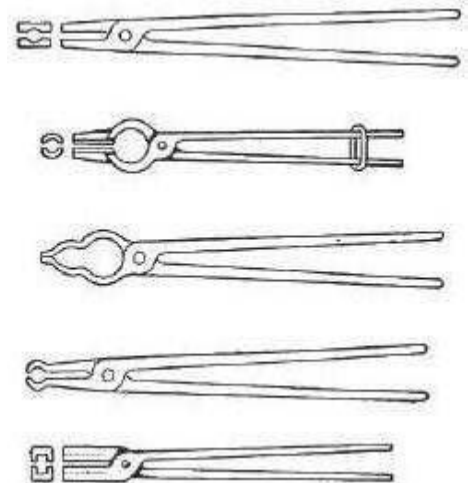
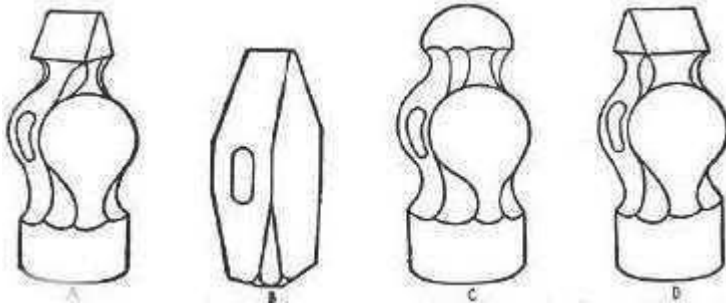

### ANVIL

# SHEET METAL



# SHEET METAL

## Introduction

Sheet metal is simply metal formed into thin and flat pieces. It is one of the fundamental forms used in metalworking, and can be cut and bent into a variety of different shapes. Countless everyday objects are constructed of the material. Thicknesses can vary significantly, although extremely thin thicknesses are considered foil or leaf, and pieces thicker than 6 mm (0.25 in) are considered plate.

Sheet metal is available as flat pieces or as a coiled strip. The coils are formed by running a continuous sheet of metal through a roll slitter.

The thickness of the sheet metal is called its gauge. The gauge of sheet metal ranges from 30 gauge to about 8 gauge. The higher the gauge, the thinner the metal is.

There are many different metals that can be made into sheet metal, such as aluminum, brass, copper, steel, tin, nickel and titanium. For decorative uses, important sheet metals include silver, gold, and platinum (platinum sheet metal is also utilized as a catalyst.)

Sheet metal has applications in car bodies, airplane wings, medical tables, roofs for building and many other things. Sheet metal of iron and other materials with high magnetic permeability, also known as laminated steel cores, has applications in transformers and electric machines. Historically, an important use of sheet metal was in plate armor worn by cavalry, and sheet metal continues to have many decorative uses, including in horse tack.

## Sheet metal processing

The raw material for sheet metal manufacturing processes is the output of the rolling process. Typically, sheets of metal are sold as flat, rectangular sheets of standard size. If the sheets are thin and very long, they may be in the form of rolls. Therefore the first step in any sheet metal process is to cut the correct shape and sized 'blank' from larger sheet.

## Sheet metal processes

Sheet metal processes can be broken down into two major classifications and one minor classification

- **Shearing processes** - processes which apply shearing forces to cut, fracture, or separate the material.
- **Forming processes** - processes which cause the metal to undergo desired shape changes without failure, excessive thinning, or cracking. This includes bending and stretching.
- **Finishing processes** - processes which are used to improve the final surface characteristics.

## Shearing Process

1. **Punching:** shearing process using a die and punch where the interior portion of the sheared sheet is to be discarded.
2. **Blanking:** shearing process using a die and punch where the exterior portion of the shearing operation is to be discarded.
3. **Perforating:** punching a number of holes in a sheet
4. **Parting:** shearing the sheet into two or more pieces
5. **Notching:** removing pieces from the edges
6. **Lancing:** leaving a tab without removing any material

## Forming Processes

- **Bending:** forming process causes the sheet metal to undergo the desired shape change by bending without failure. Ref fig.
- **Stretching:** forming process causes the sheet metal to undergo the desired shape change by stretching without failure.
- **Drawing:** forming process causes the sheet metal to undergo the desired shape change by drawing without failure.
- **Roll forming:** Roll forming is a process by which a metal strip is progressively bent as it passes through a series of forming rolls.

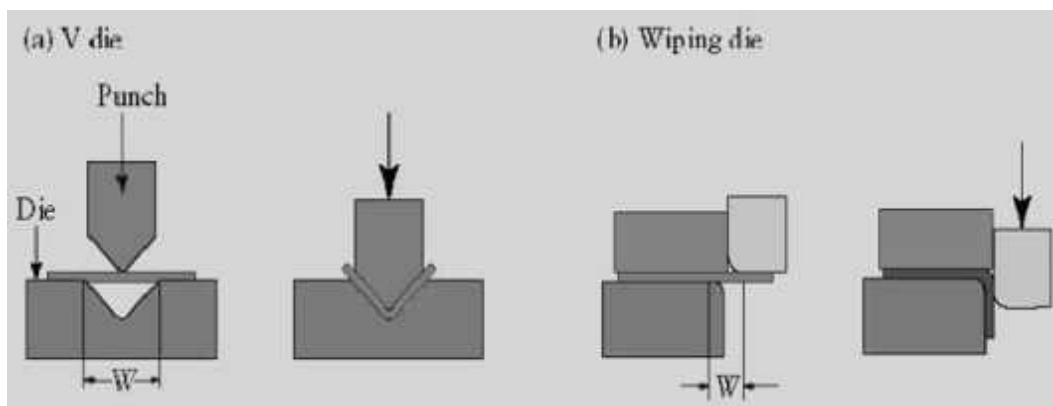

## Common Die – Bending operations

### Finishing processes

Material properties, geometry of the starting material, and the geometry of the desired final product play important roles in determining the best process

### Equipments

Basic sheet forming operations involve a press, punch, or ram and a set of dies

### Presses

- **Mechanical Press** - The ram is actuated using a flywheel. Stroke motion is not uniform.
- **Hydraulic Press** - Longer strokes than mechanical presses, and develop full force throughout the stroke. Stroke motion is of uniform speed, especially adapted to deep drawing operations.

### Dies and Punches

- **Simple**- single operation with a single stroke
- **Compound**- two operations with a single stroke
- **Combination**- two operations at two stations
- **Progressive**- two or more operations at two or more stations with each press stroke, creates what is called a strip development

### Tools and Accessories:

The various operations such as cutting, shearing, bending, folding etc. are performed by these tools.

### Marking and measuring tools

- **Steel Rule** - It is used to set out dimensions.
- **Try Square** - Try square is used for making and testing angles of 90degree
- **Scriber** – It used to scribe or mark lines on metal work pieces.
- **Divider** - This is used for marking circles, arcs, laying out perpendicular lines, bisecting lines, etc

### Cutting Tools

- **Straight snip** - They have straight jaws and used for straight line cutting. Ref fig.

- **Curved snip** - They have curved blades for making circular cuts. Ref fig.

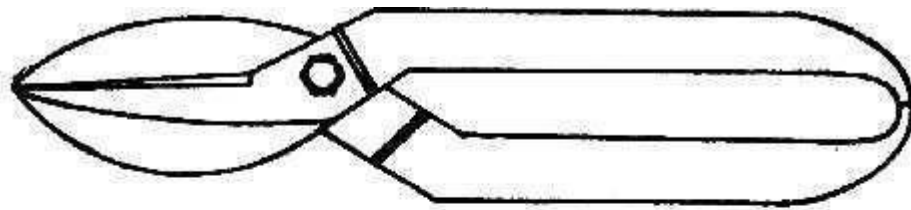

**STRAIGHT SNIP**

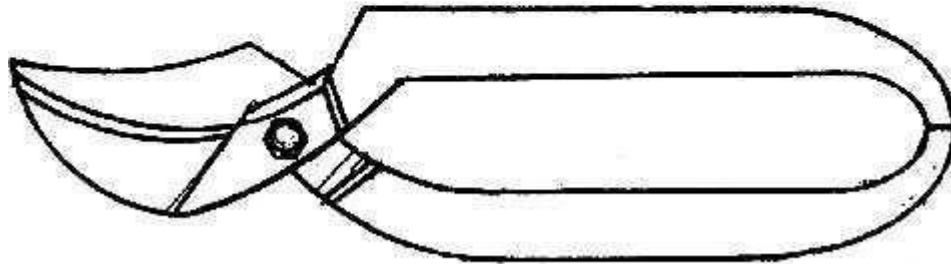

**CURVED SNIP**



**CENTRE PUNCH**

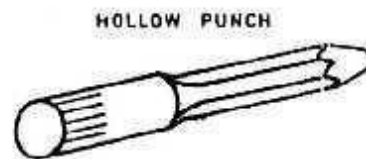

**HOLLOW PUNCH**

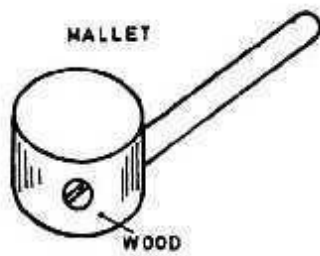

**MALLET**

**WOOD**

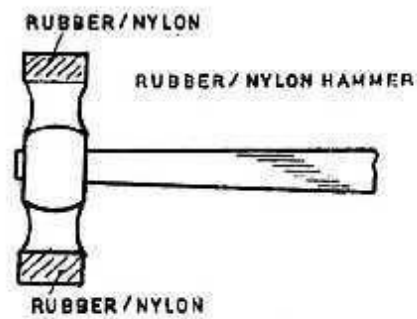

**RUBBER/NYLON**

**RUBBER/NYLON HAMMER**

**RUBBER/NYLON**

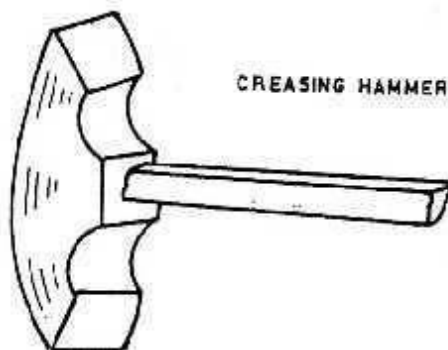

**CREASING HAMMER**

## **Striking Tools**

**Mallet** - It is wooden-headed hammer of round or rectangular cross section. The striking face is made flat to the work. A mallet is used to give light blows to the Sheet metal in bending and finishing.

**Hammers** – Hammers are also used in sheet metal work for forming shapes. Commonly used hammers are rubber / nylon hammers and creasing hammer.

### **Merits**

- High strength
- Good dimensional accuracy and surface finish
- Relatively low cost

### **Demerits**

Wrinkling and tearing are typical limits to drawing operations

Different techniques can be used to overcome these limitations

- Draw beads
- Vertical projections and matching grooves in the die and blank holder

Trimming may be used to reach final dimensions

### **Applications**

- Roofing Dustings
- Vehicles body buildings like 3 wheelers, 4 wheelers, ships, aircrafts etc.Furniture,
- House hold articles and Railway equipment

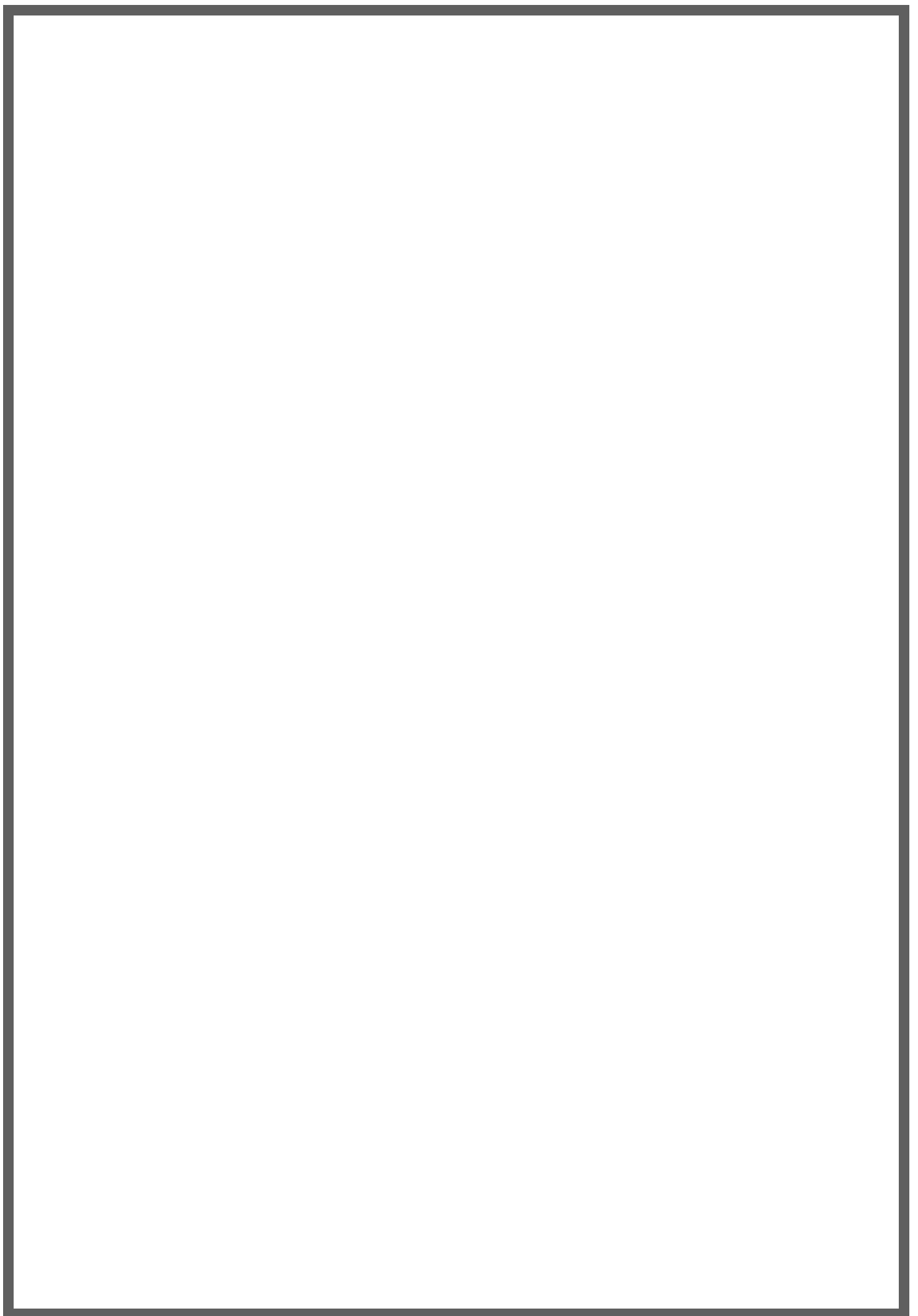

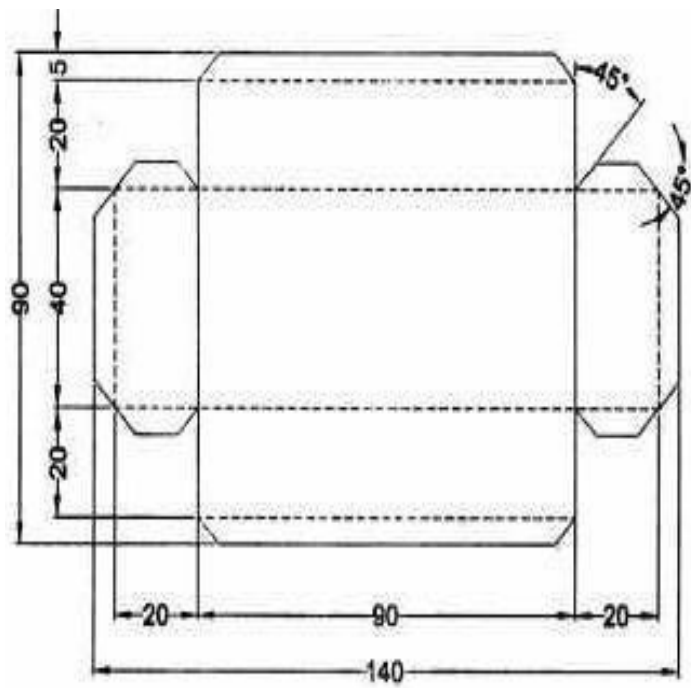

FLAPS-RIVETING

Edge Hemming out side

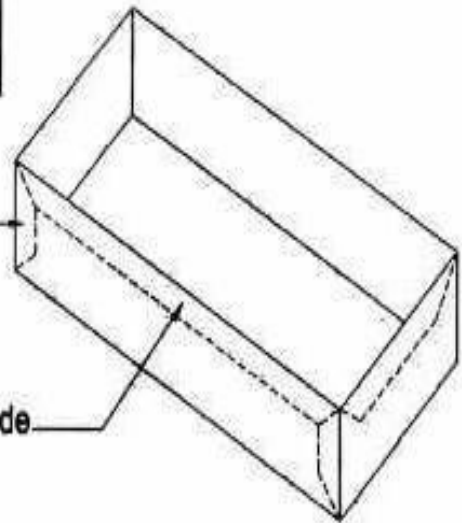

All dimensions are in mm

<b>TRAY MAKING</b>	
<b>DATE:</b>	<b>EX.NO.7</b>

**Aim:** To make a rectangular tray out of the given sheet with specified dimensions.

**Tools/Apparatus required:**

1. Sheet metal
2. Anvil
3. Try square
4. Steel rule
5. Divider
6. Snip
7. Scriber
8. Mallet
9. File
10. Hand shearing machine
11. Protractor etc.

**Materials required:**

Galvanized Iron Sheet.

**Procedure:**

1. Development of the rectangular tray for the given dimensions is drawn on the provided sheet metal using steel rule, protractor and scriber as shown in fig.
2. Assume some joining allowance on all sides of the development for locking the tray.
3. The sheet metal is exactly cut as per the markings made on it using a hand shearing machine or snip. The burrs are removed using a file.
4. Single hemming is made on the four sides of the tray as shown in fig.
5. Four sides are bent to 90° using stake / anvil.
6. Then the edges are bent for the length of joining allowance and the edges are made to overlap each other and are struck with a mallet to get the required joint.

**Result:**

Thus the rectangular tray of given dimension is fabricated with the given sheet metal.



## DEVELOPMENT OF FUNNEL CONE

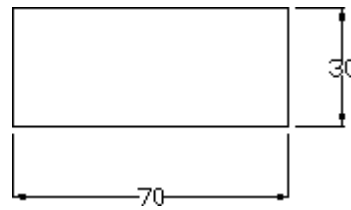
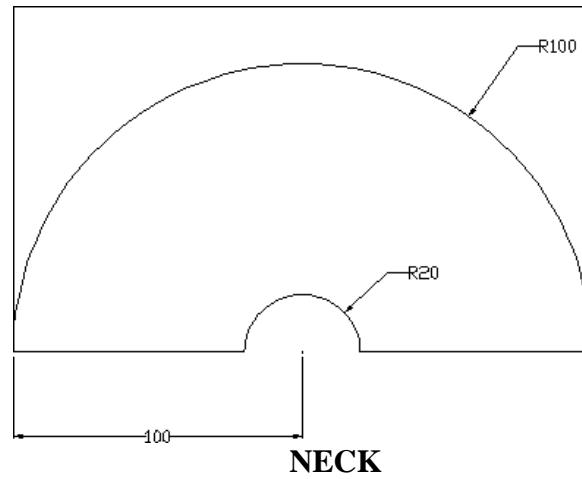

*All dimensions are in mm.*

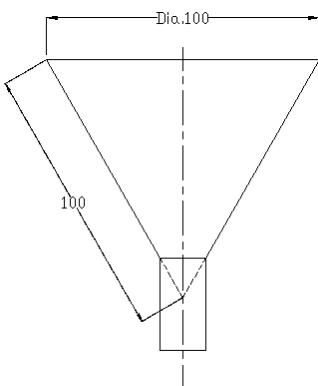

$$\text{Slant height } L = \sqrt{100^2 + 50^2} = 112$$

$$\begin{aligned} \text{ANGLE } \phi &= (R/L) \times 360^\circ \\ &= (50/100) \times 360^\circ \\ &= 180^\circ \end{aligned}$$

<b>FUNNEL MAKING</b>	
<b>DATE:</b>	<b>EX.NO.8</b>

**Aim:**

To make the funnel from the given sheet metal.

**Material Required:**

26 gauge Galvanized Iron (G.I) Sheet [200x100mm]

**Tools required:**

Steel Rule, Scriber, Try-Square, Ball Peen Hammer, Mallet, Stacks, Straight Snip, Groover, Pliers and Compass.

**Sequence of Operation:**

- a. Marking
- b. Cutting
- c. Hemming
- d. Bending
- e. Finishing

**Working Steps**

1. unnel is splitted into cone and cylinder
2. The development of cone and cylinder are drawn on the given GI sheet, using steel rule, scriber and compass.
3. The unwanted portion of the sheet is cut by using the straight snip along the markedlines.
4. Then the sheet is levelled for the perfect flatness using the mallet.
5. The position of the hemming operation is marked at the top edge of the cone and also at the bottom edge of the cylinder, with the help of the steel rule and a scriber as per the specification given in the sketch.
6. The cone and the cylinder are joined together by seaming operation and soldering is done around the joint.
7. Hemming is done at the top and bottom of the funnel by using required stacks and mallets
8. Finally finishing operation is done to aviod ups and downs of the funnel

**Result:**

Thus the funnel of given dimension is fabricated with the given sheet metal.

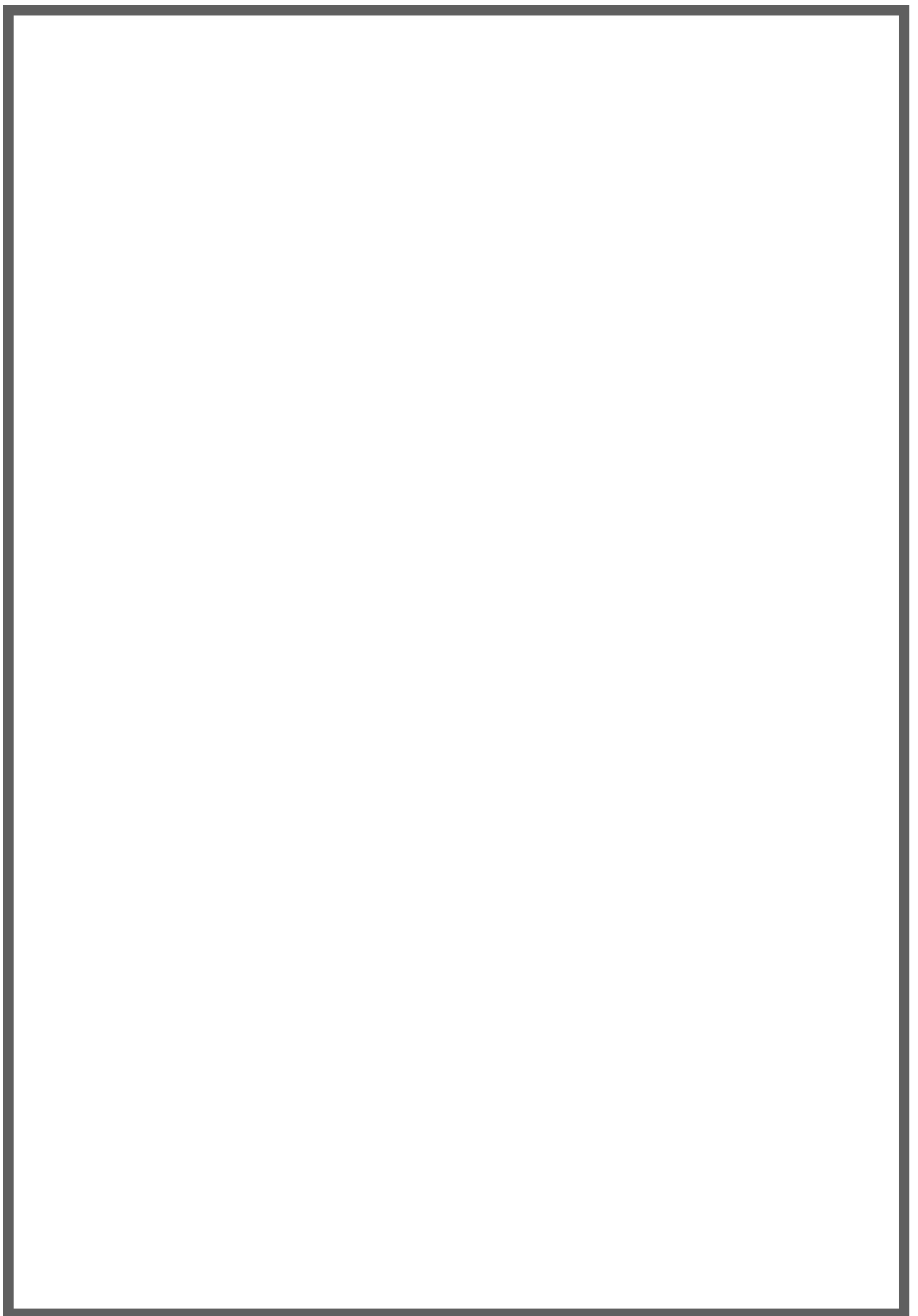

## ASSEMBLING OF CENTRIFUGAL PUMP

DATE:

EX.NO.9

A centrifugal pump is one of the simplest pieces of equipment in any process plant. Its purpose is to convert energy of a prime mover (a electric motor or turbine) first into velocity or kinetic energy and then into pressure energy of a fluid that is being pumped.

The energy changes occur by virtue of two main parts of the pump, the impeller and the volute or diffuser. The impeller is the rotating part that converts driver energy into the kinetic energy. The volute or diffuser is the stationary part that converts the kinetic energy into pressure energy.

Note: All of the forms of energy involved in a liquid flow system are expressed in terms of feet of liquid i.e. head.

### Generation of Centrifugal Force

The process liquid enters the suction nozzle and then into eye (center) of a revolving device known as an impeller. When the impeller rotates, it spins the liquid sitting in the cavities between the vanes outward and provides centrifugal acceleration. As liquid leaves the eye of the impeller, a low-pressure area is created causing more liquid to flow toward the inlet. Because the impeller blades are curved, the fluid is pushed in a tangential and radial direction by the centrifugal force. This force acting inside the pump is the same one that keeps water inside a bucket that is rotating at the end of a string. Figure below depicts a side cross-section of a centrifugal pump indicating the movement of the liquid.

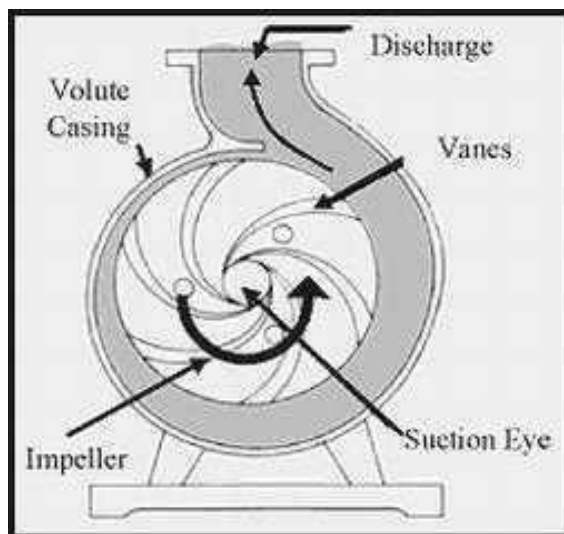

## **Conversion of Kinetic Energy to Pressure Energy**

The key idea is that the energy created by the centrifugal force is kinetic energy. The amount of energy given to the liquid is proportional to the velocity at the edge or vane tip of the impeller. The faster the impeller revolves or the bigger the impeller is, then the higher will be the velocity of the liquid at the vane tip and the greater the energy imparted to the liquid.

This kinetic energy of a liquid coming out of an impeller is harnessed by creating a resistance to the flow. The first resistance is created by the pump volute (casing) that catches the liquid and slows it down. In the discharge nozzle, the liquid further decelerates and its velocity is converted to pressure according to Bernoulli's principle.

Therefore, the head (pressure in terms of height of liquid) developed is approximately equal to the velocity energy at the periphery of the impeller

This head can also be calculated from the readings on the pressure gauges attached to the suction and discharge lines.

## **General Components of Centrifugal Pumps**

A centrifugal pump has two main components:

- I. A rotating component comprised of an impeller and a shaft
- II. A stationary component comprised of a casing, casing cover, and bearings.

## ASSEMBLING OF HOUSEHOLD MIXER

DATE:

EX.NO.10

### HOUSEHOLD MIXER

Mixer grinders are an important part of Indian kitchens, indispensable and necessary. Cooking without a mixer grinder can become very difficult and time-consuming. They play an important role in grinding masalas, which were earlier done on a grinding stone, also called a *sil-batta* in India. They are used for pureeing, mixing, grinding, and some mincing.

Mixer grinders are designed for multiple tasks. In general, a mixer grinder has separate jars – Liquidiser jar, Grinder Jar, and Chutney Jar. Over the years, mixer grinders have become sleeker, lighter, and easy to use with aesthetically designed looks.

#### 1. POWER

Power or Wattage decides how much and how well can the mixer grinder do its work. Higher power is useful for grinding tougher ingredients and at a faster speed. The Indian market has power/wattage options starting from 450W. Usually, for Indian kitchens, anything from 450 W to 750 W is sufficient.

#### 2. SPEED

The speed or RPM of a mixer grinder tells you how fast the blades rotate in a minute. Indian kitchens and their mixing-grinding needs necessitate the speed to be more than 18000 RPM. Usually, the upper limit of the speed at 23000 RPM is good. It is however important for the mixer grinders to have a speed control knob or a switch to change the settings as per mixing or grinding requirement.

#### 3. JARS

The next important element is the Jar. As is the case with most things in life, the more the merrier. Standard mixer grinders provide 2 – 3 jars, one for liquidising, one for grinding, and one for chutney-making. The jars must be of stainless steel, must have a good break-resistant lid and a good handle.

#### 4. BLADES

The blades do the real work, of grinding and mixing. In that sense, they become a critical part of the product. The blade is usually made of high-grade steel. It should be of grade 304, which is resistant to oxidation and corrosion. Such blades also retain their sharpness for a longer time.

#### Mixer Grinder Keeps Tripping

There is a reset button placed under the mixer grinder which trips when you continuously use the appliance for longer hours or grind hot food items. The next time you experience this problem, avoid using the appliance for too long and allow the food to cool down before you grind it. If the mixer grinder trips due to excessive heat, unplug the appliance, remove the jar and look under the appliance. At the bottom of the unit you will see a red switch. Press the switch to reset the appliance, plug it back in, switch it on and this should solve the problem.

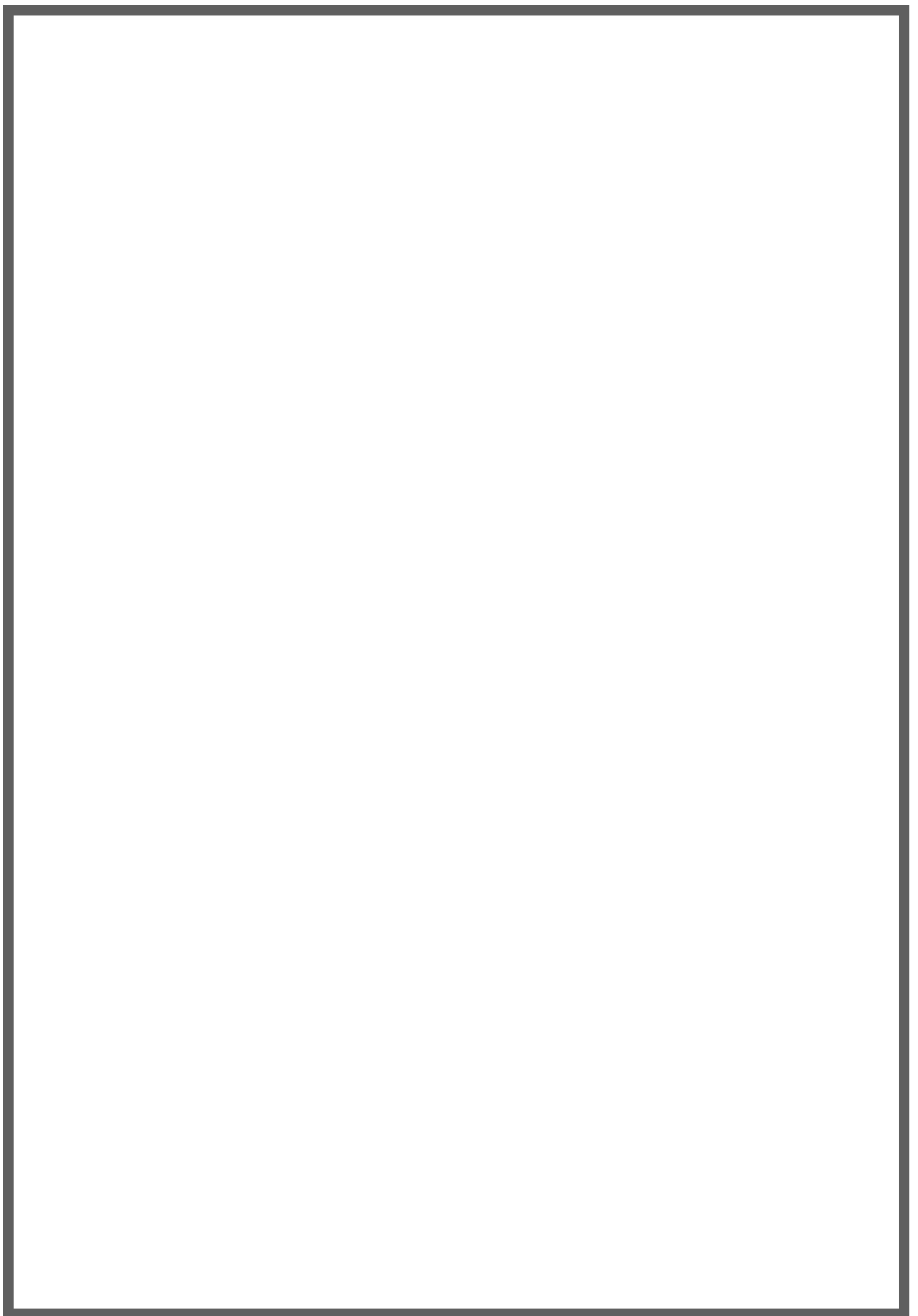

## 10. AIR CONDITIONING

An air conditioner is an appliance, system, or mechanism designed to extract heat from an area using a refrigeration cycle. In construction, a complete system of heating, ventilation, and air conditioning is referred to as HVAC. Its purpose, in the home or in the car, is to provide comfort during either hot or cold weather.

### Air conditioning system basics and theories

#### Refrigeration cycle

A simple diagram of the refrigeration cycle contains 1) condensing coil, 2) expansion valve, 3) evaporator coil, 4) compressor. In the refrigeration cycle, a heat pump transfers heat from a lower temperature heat source into a higher temperature heat sink. Heat would naturally flow in the opposite direction. This is the most common type of air conditioning. A refrigerator works in much the same way, as it pumps the heat out of the interior into the room in which it stands.

This cycle takes advantage of the way phase changes work, where latent heat is released at a constant temperature during a liquid/gas phase change, and where a different pressure of a pure substance means that it will condense/boil at a different temperature.

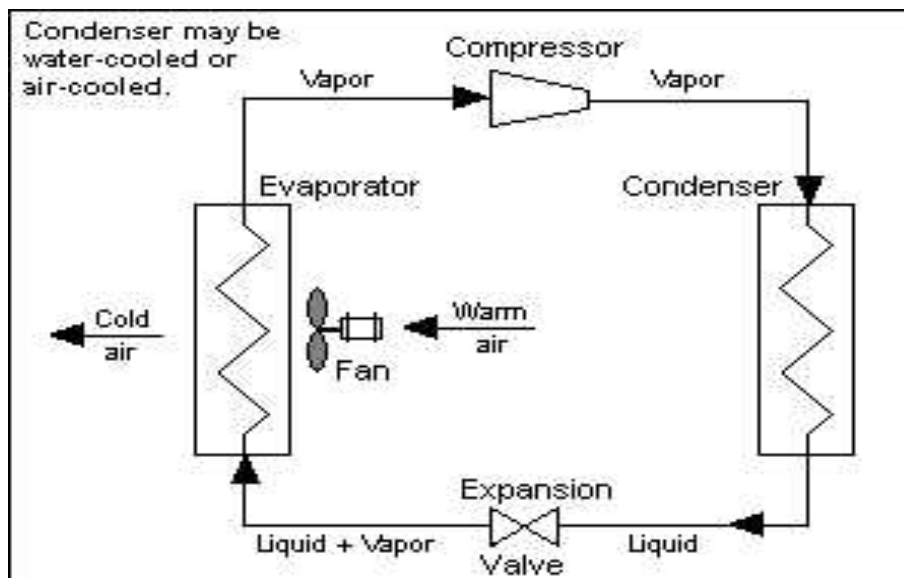



The most common refrigeration cycle uses an electric motor to drive a compressor. In an automobile, the compressor is driven by a belt over a pulley, the belt being driven by the engine's crankshaft (similar to the driving of the pulleys for the alternator, power steering, etc.). Whether in a car or the house, both use electric fan motors for air circulation. Since evaporation occurs when heat is absorbed, and condensation occurs when heat is released, air conditioners are designed to use a compressor to cause pressure changes between two compartments, and actively condense and pump a refrigerant around.

A refrigerant is pumped into the cooled compartment (the evaporator coil), where the low pressure and low temperature cause the refrigerant to evaporate into a vapor, taking heat with it. In the other compartment (the condenser), the refrigerant vapor is compressed and forced through another heat exchange coil, condensing into a liquid, rejecting the heat previously absorbed from the cooled space and the cycle repeats to keep the system at the required temperature.

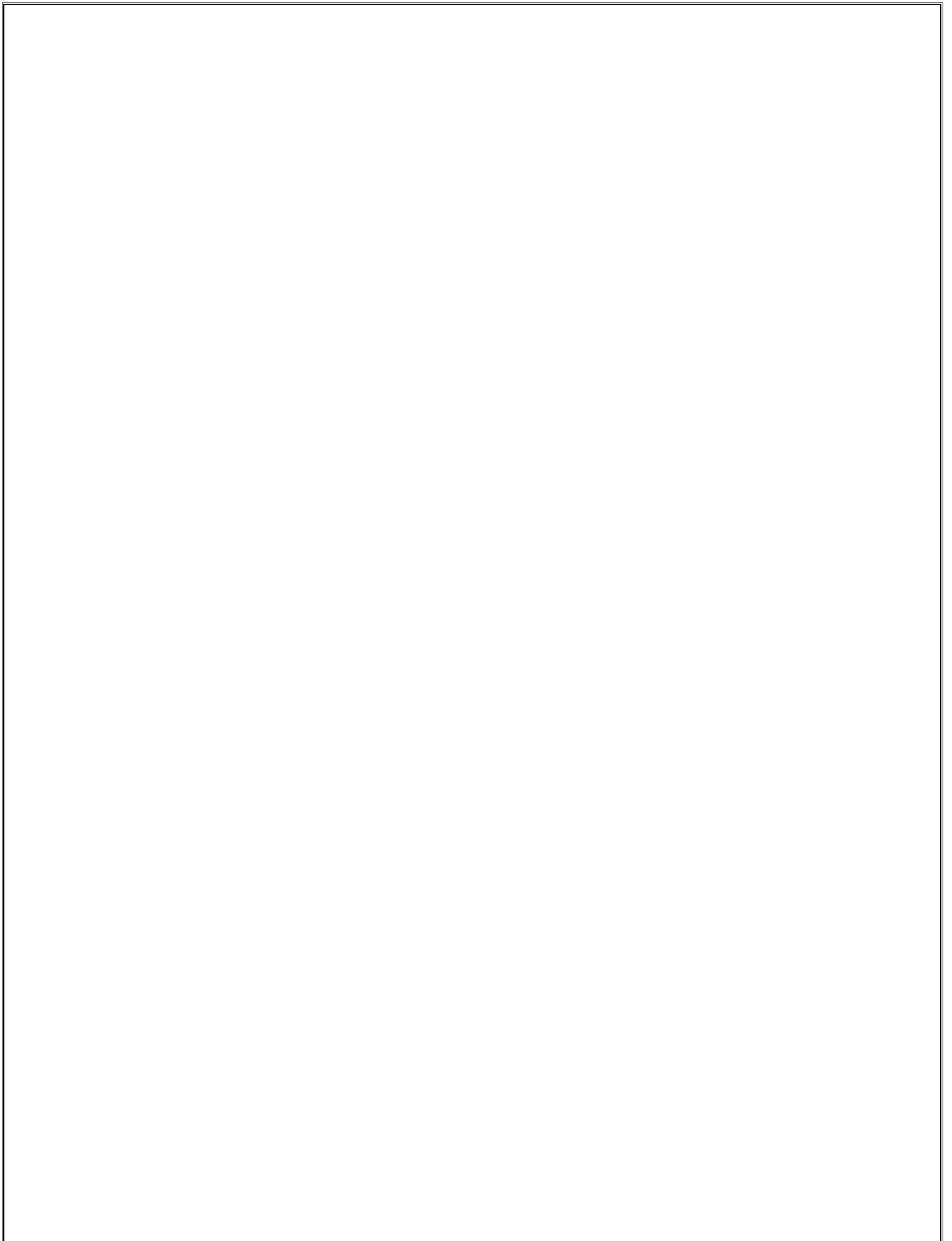

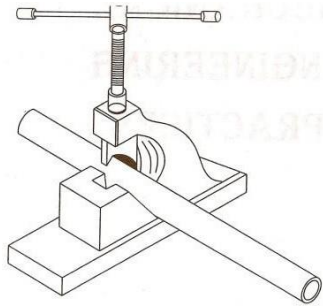

Pipe Vice

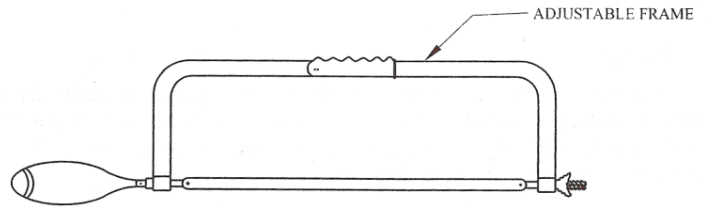

HACK SAW WITH ADJUSTABLE FRAME

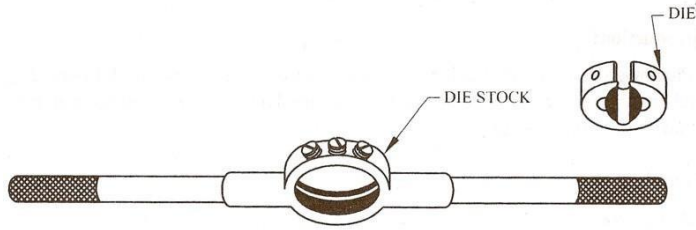

DIE SET

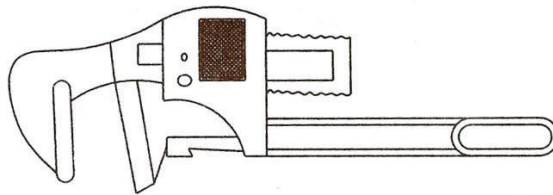

PIPE WRENCH

# PLUMBING

## Introduction:

Plumbing also refers to a system of pipes and fixtures installed in a building for the distribution of potable water and the removal of waste water. Plumbing is the skilled trade of working with pipes, tubing and plumbing fixtures for drinking water systems and the drainage of waste. A plumber is someone who installs or repairs piping systems, plumbing fixtures and equipment such as water heaters. The plumbing industry is a basic and substantial part of every developed economy due to the need for clean water, and proper collection and transport of wastes. In addition to the straight pipe or tubing, many fittings are required in plumbing systems, such as valves, elbows, tees, and unions.

## Plumbing Tools:

1. Pipe wrench
2. Pipe vice
3. Pipe cutter
4. Die set
5. Hack saw

### 1. Pipe wrench:

The pipe wrench is an adjustable wrench used for turning soft iron pipes and fittings with a rounded surface. The design of the adjustable jaw allows it to rock in the frame, such that any forward pressure on the handle tends to pull the jaws tighter together. Teeth angled in the direction of turn dig into the soft pipe.

### 2. Pipe vice:

The pipe vice is used to hold the pipes rigidly in position during thread cutting and fitting of bends, valves, couplings etc. it consists of fixed jaw and movable jaw to hold the work piece and a screw rod with handle is used for an adjustment. This vice is fixed on the work bench.

### 3. Pipe cutter:

A pipe cutter is a type of tool used by plumbers to cut pipe. Besides producing a clean cut, the tool is often a faster and more convenient way of cutting pipe than using a hacksaw, although this depends on the metal the pipe is made out of. There are two types of pipe cutters. Plastic tubing cutters, which really look much like a pair of pruning shears, may be used for thinner pipes and tubes such as a

INTERNAL V  
THREADS

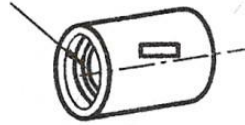

COUPLING

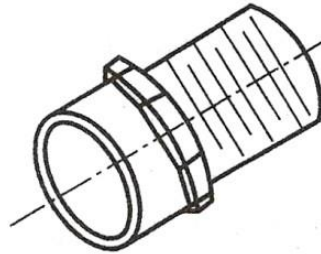

BUSH WITH THREADS

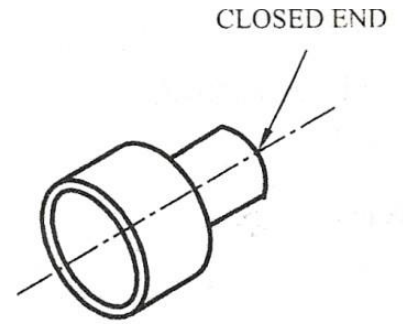

CAP

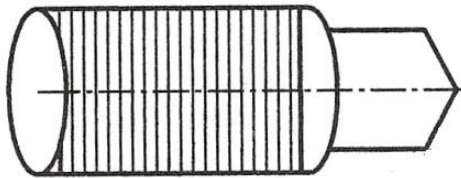

PLUG

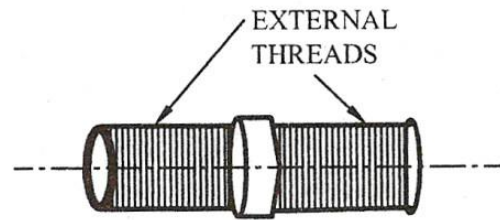

NIPPLE

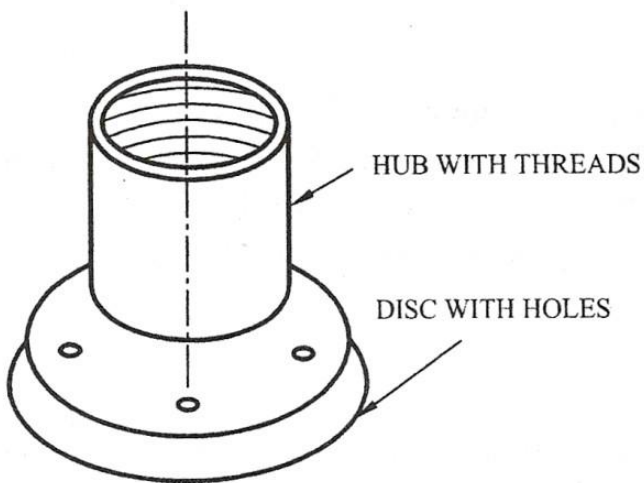

FLANGE

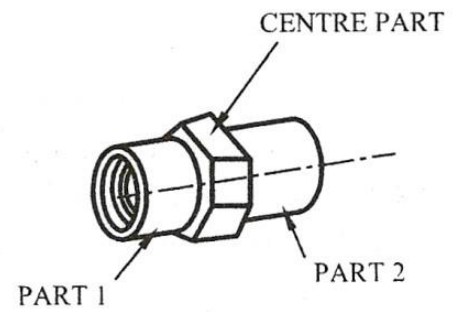

UNION

Sprinkler pipe. Then there is a pipe cutter with a sharp wheel and adjustable jaw grips for use on thicker pipes. These are used by rotating it around the pipe and repeatedly tightening it until it.

#### 4. Die set:

A die head is a threading die that is used in the high volume production of threaded components. They may be used for either cutting a thread or rolling a thread. They may also be used for internal or external thread cutting.

#### 5. Hack saw:

A hacksaw is a fine-tooth saw with a blade under tension in a frame, used for cutting materials such as metal. Hand-held hacksaws consist of a metal arch with a handle, usually a pistol grip, with pins for attaching a narrow disposable blade. A screw or other mechanism is used to put the thin blade under tension. The blade can be mounted with the teeth facing toward or away from the handle, resulting in cutting action on either the push or pull stroke.

### Pipes & Pipe Fittings:

#### **Pipes:**

Threaded pipe is often used in plumbing and pneumatic applications. Because pipe joints must form a seal, the threaded portion is slightly conical rather than cylindrical. As a result, threaded pipe requires specialized taps and dies. A modified form of the basic pipe thread shape is the Dry-Seal thread. The Dry-Seal thread is formed so that during assembly, the tips of the male threads are slightly crushed into the roots of the female threads, affecting, in theory, a liquid-tight fit.

The pipes may be made up of different types like Plastic pipe, Galvanized Iron (GI) pipe, Mild steel pipe, Cast iron pipe, Copper pipe, Brass pipe, Lead pipe, Rubber pipe, Fiber pipe, Polythene pipe.

### Pipe Fittings:

Fittings are used in pipe and plumbing systems to connect straight pipe or tubing sections, to adapt to different sizes or shapes, and to regulate fluid flow.

#### a) Elbow:

A pipe fitting installed between two lengths of pipe or tube allowing a change of direction, usually 90° or 45°. The ends may be machined for butt welding, threaded. When the two ends differ in size, it is called a reducing or **reducer elbow**.

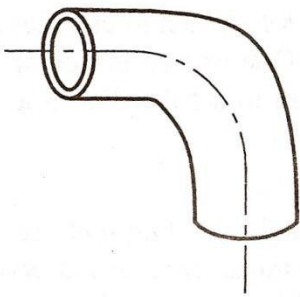

BEND

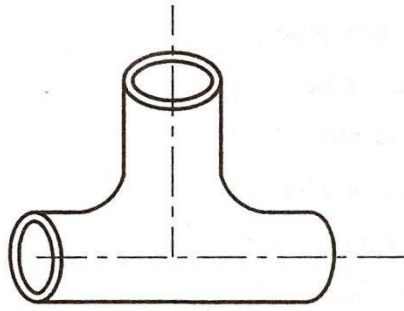

TEE

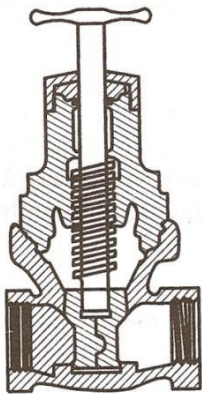

GATE VALVE

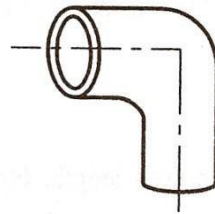

ELBOW

**b) Tee:**

A tee is used to either combine or split a fluid flow. Most common are tees with the same inlet and outlet sizes, but '**reducing**' tees are available as well.

**c) Cap:**

A type of pipe fitting, often liquid or gas tight, which covers the end of a pipe. A cap has a similar function to a plug.

**d) Plug:**

A plug closes off the end of a pipe. It is similar to a cap but it fits inside the fitting.

**e) Nipple:**

Short stub of pipe, usually threaded iron, A nipple is defined as being a short stub of pipe which has two male ends. Nipple is commonly used for plumbing and hoses, and second as valves for funnels and pipes.

**f) Coupling:**

A coupling connects two pipes to each other. If the material and size of the pipe are not the same, the fitting may be called a 'reducing coupling' or reducer, or an adapter.

**g) Union:**

A union is similar to a coupling, except it is designed to allow quick and convenient disconnection of pipes for maintenance or fixture replacement.

**h) Valve:**

A valve is a device that regulates the flow of a fluid (gases, fluidized solids, slurries, or liquids) by opening, closing, or partially obstructing various passageways. Plumbing valves, such as taps for hot and cold water are the most noticeable types of valves. Valves may be operated manually, either by a hand wheel, lever or pedal.

**i) Wrench:**

A wrench or spanner is a tool used to provide a mechanical advantage in applying torque to turn bolts, nuts or other items designed to interface with a wrench.



**j) Flange:**

Flanges are largely used for pipe joints. Flange joint may be made with flanges which are cast integral with the pipes (or) loose flanges which are welded (or) screwed with pipes.

**k) Bush:**

It is a short sleeve like piece which is used to reduce the size of a threaded opening.

**Applications of Plumbing**

The major categories of plumbing systems or subsystems are:

- Potable cold and hot water supply
- Traps, drains, and vents
- Septic systems
- Rainwater, surface, and subsurface water drainage
- Fuel gas piping

# PLUMBING EXERCISES

# PIPE LAYOUT

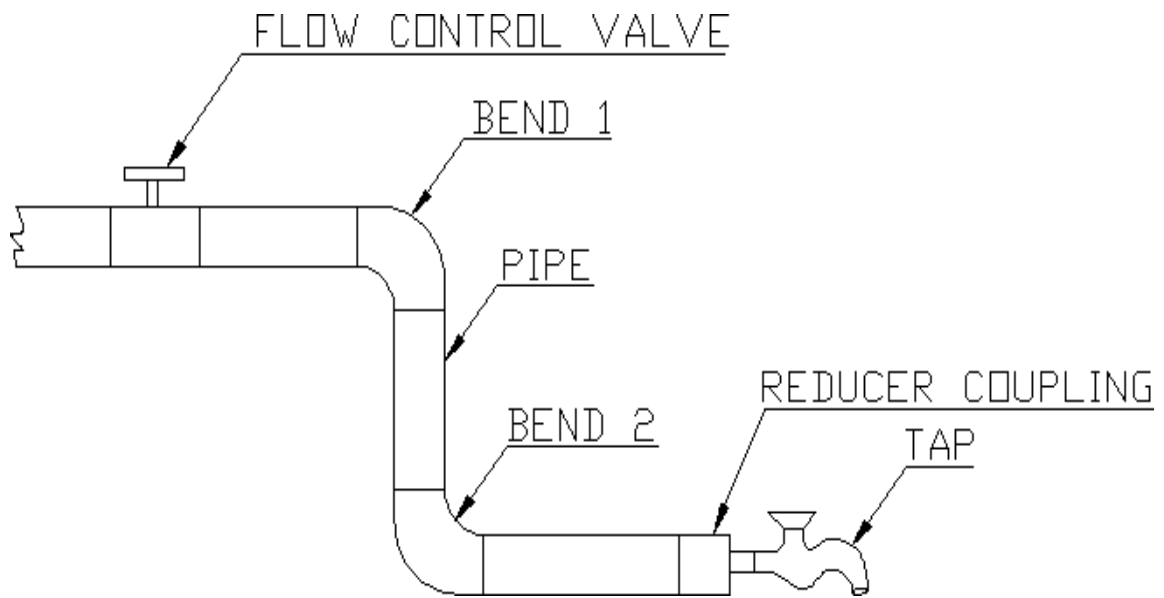

<b>BASIC CONNECTION INVOLVING PVC / GI PIPES AND PIPE FITTINGS</b>	
<b>DATE:</b>	<b>EX.NO.12</b>

**Aim:**

To connect the PVC / GI pipe with pipe fittings like valves, bends and tap.

**Fittings and Components Required:**

1. Pipes of different length
2. Gate valve
3. Tap
4. Elbows
5. Reducer

**Tools required:**

Pipe wrench, Hack saw, Die set, Hammer, Screw driver, Measuring tape.

**Sequence of Operation:**

- a) Selection of pipes.
- b) Threading of pipes.
- c) Connection of the pipes with the pipe fittings

**Working Steps:**

1. The required pipe connection layout is drawn.
2. Two pipes of required lengths are taken and the ends are threaded using die set.
3. The gate valve which is internally threaded is connected between two pipes. The other end of the pipe is connected with the elbow which is also internally threaded.
4. A third pipe, with external threads is connected to the elbow for vertical extension.
5. To this pipe another elbow is attached at the free end.
6. The free end of the second elbow is connected with another pipe for horizontal extension.
7. A reducer coupling, with internal threads is connected to the horizontal pipe.
8. A tap is connected properly to the end of the reducer coupling.

**Result:**

Hence the required connection is obtained using required pipes and pipe fittings.

# PIPE CONNECTIONS FOR WASHBASIN

## DOUBLE LINE DIAGRAM

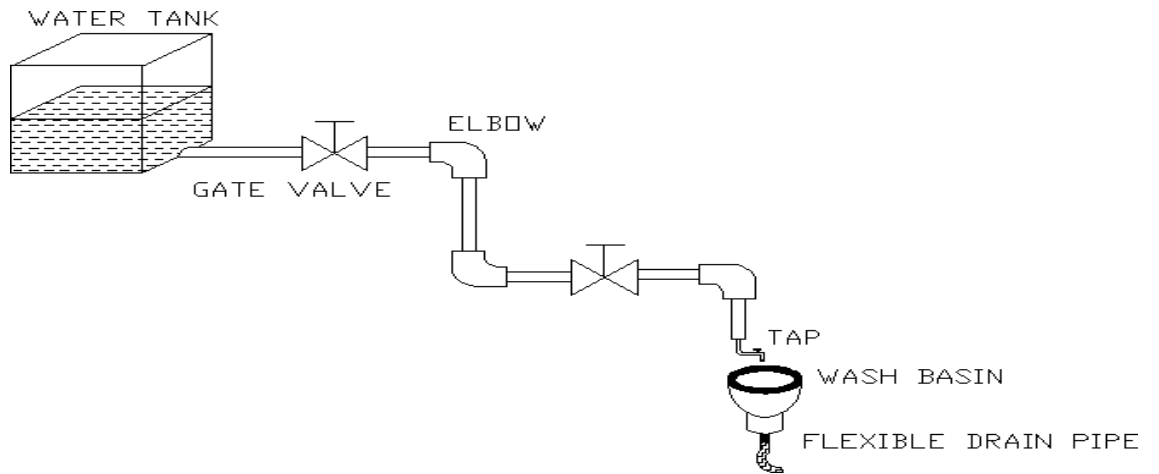

## SINGLE LINE DIAGRAM

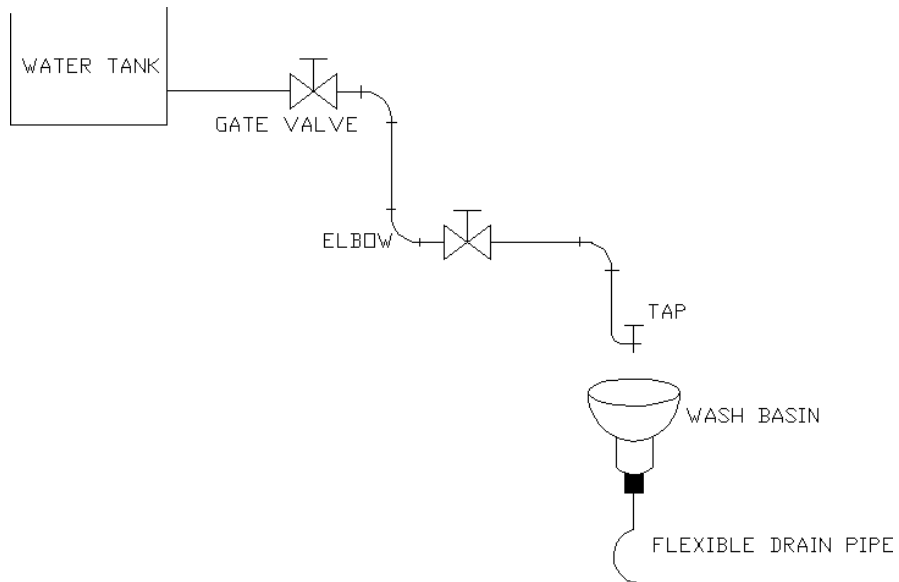

## PREPARATION OF PIPE LINE FROM A WATER TANK TO WASH BASIN

**DATE:**

**EX.NO.13**

**Aim:**

To prepare a pipe line from a water tank to a wash basin.

**Fittings and Components Required:**

1. Wash basin
2. Gate valves
3. Connecting pipes of different lengths.
4. Flexible pipes for inlet and drain.
5. Pipe fittings like tee-joint, elbow

**Tools required:**

Pipe wrench, Hack saw, Die set, Hammer and measuring tape.

**Sequence of Operation:**

- a. Selection of pipes of required length.
- b. Threading the ends of pipes as required.
- c. Connection of the water tank to wash basin.

**Working Steps:**

1. Mark the location of wash basin and fix it properly
2. Fix the tap on the wash basin in the required position properly
3. Draw the pipeline sketch to connect the wash basin tap with the water tank.
4. Connect the water tank and the wash basin tap using required length of pipes and pipe fittings.
5. Fix the flow control valve near the wash basin tap and connect its outlet with the tap using flexible pipe.
6. Fix the flexible drain pipe from the wash basin to the common drain outlet.

**Result:**

Hence the pipeline to the wash basin from the water tank is made.

PIPE CONNECTIONS FOR WATERHEATER

DOUBLE LINE DIAGRAM

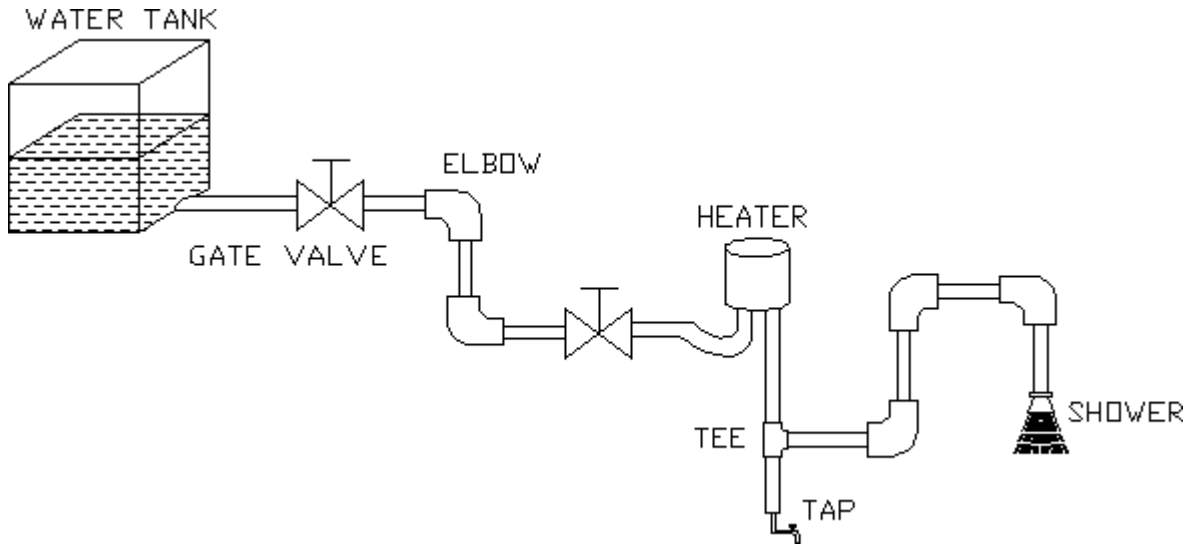

SINGLE LINE DIAGRAM

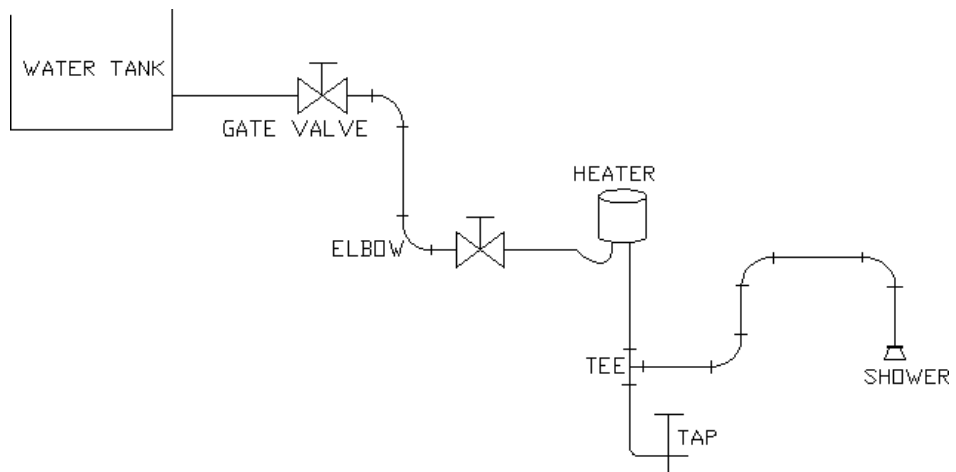

## PREPARATION OF PIPE LINE FROM A WATER TANK TO WATER HEATER

**DATE:**

**EX.NO.14**

**Aim:**

To prepare a pipe line from a water tank to water heater

**Fittings and Components Required:**

1. Water heater
2. Gate valves
3. Connecting pipes of different lengths.
4. Pipe fittings like tee-joint, elbow
5. A tap
6. Shower

**Tools required:**

Pipe wrench, Hack saw, Die set, Hammer and measuring tape.

**Sequence of Operation:**

- a. Selection of pipes of required length.
- b. Threading the ends of pipes as required.
- c. Connection of the water tank to water heater.
- d. Connection of the water heater to tap and/or shower.

**Working Steps:**

1. Mark the location of water heater and draw the pipe line diagram.
2. Fix the water heater in the required position using required number of clamps.
3. Connect the water tank and the water heater using required length of pipes and pipe fittings.
4. Fix the flow control valve (gate valve) near the water heater and using a flexible pipe connects the water heater inlet and control valve outlet.
5. Connect the outlet of the water heater with the shower or tap with proper pipe fittings.

**Result:**

Hence the pipeline to a water heater from the water tank is made.



# PIPE CONNECTIONS FOR WASHINGMACHINE

## DOUBLE LINE DIAGRAM

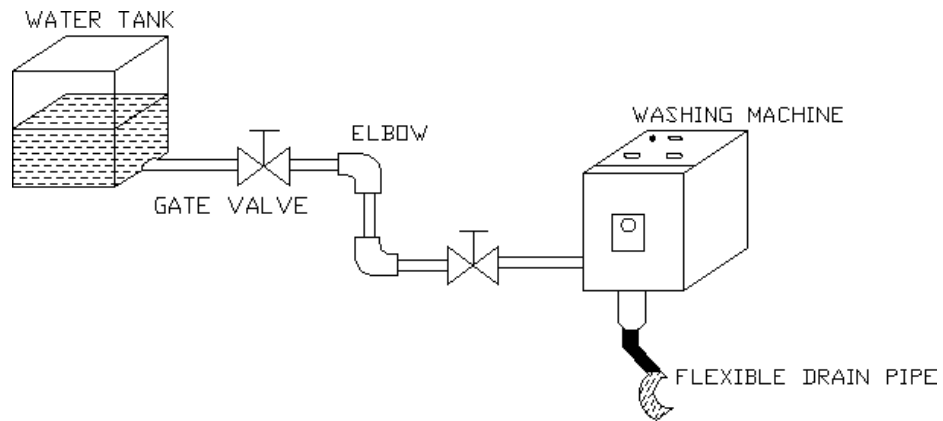

## SINGLE LINE DIAGRAM

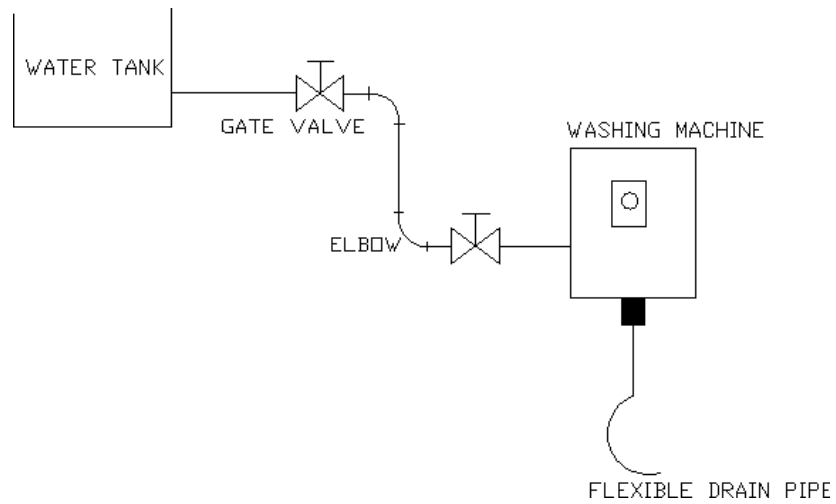

<b>PREPARATION OF PIPE LINE FROM A WATER TANK TO WASHING MACHINE</b>	
<b>DATE:</b>	<b>EX.NO.15</b>

**Aim:**

To prepare a pipe line from a water tank to washing machine

**Fittings and Components Required:**

1. Washing Machine
2. Gate valves
3. Connecting pipes of different lengths.
4. Flexible pipe for inlet and drain for washing machine.
5. Pipe fittings like tee-joint, elbow, reducer and coupling.

**Tools required:**

Pipe wrench, Hack saw, Die set, Hammer and measuring tape.

**Sequence of Operation:**

- a. Selection of pipes of required length.
- b. Threading the ends of pipes as required.
- c. Connection of the water tank to washing machine.

**Working Steps:**

1. Mark the location of water heater and the pipe line diagram is prepared accordingly.
2. Connect the water tank and the washing machine using required length of pipes and pipe fittings.
3. Fix the flow control valve near the washing machine.
4. Connect the gate valve outlet and the washing machine inlet using a flexible pipe.
5. Fix the flexible drain pipe from the washing machine to the common drain outlet.

**Result:**

Hence the pipeline to the washing machine from the water tank is made.

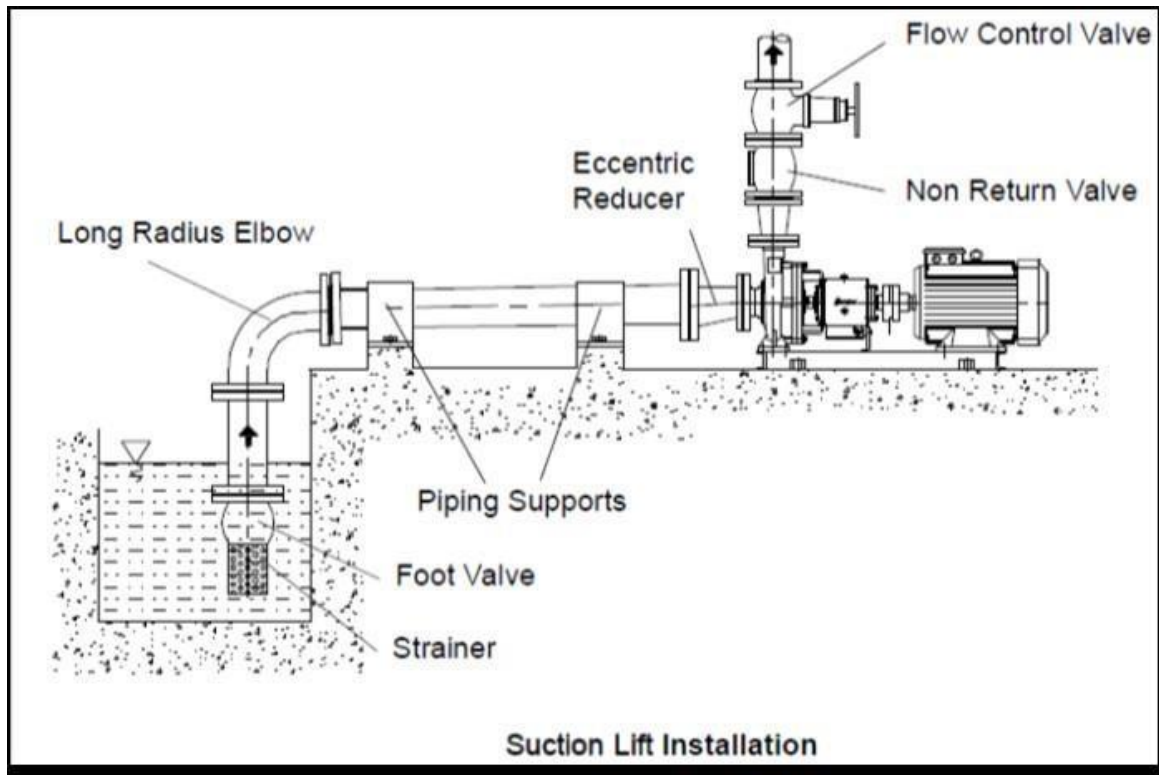

Laying pipe connection to the suction side of a pump

**DATE:**

**EX.NO.16**

**Aim:**

To connect the PVC / GI pipe with pipe fittings like valves, bends and tap.

**Fittings and Components Required:**

Pipes of different length  
Gate valve  
Tap  
Elbows  
Reducer

**Tools required:**

Pipe wrench, Hack saw, Die set, Hammer, Screw driver, Measuring tape.

**Sequence of Operation:**

- d) Selection of pipes.
- e) Threading of pipes.
- f) Connection of the pipes with the pipe fittings

**Working Steps:**

9. The required pipe connection layout is drawn.
10. Two pipes of required lengths are taken and the ends are threaded using die set.
11. The gate valve which is internally threaded is connected between two pipes. The other end of the pipe is connected with the elbow which is also internally threaded.
12. A third pipe, with external threads is connected to the elbow for vertical extension.
13. To this pipe another elbow is attached at the free end.
14. The free end of the second elbow is connected with another pipe for horizontal extension.
15. A reducer coupling, with internal threads is connected to the horizontal pipe.
16. A tap is connected properly to the end of the reducer coupling.

**Result:**

Hence the required connection is obtained using required pipes and pipe fittings.

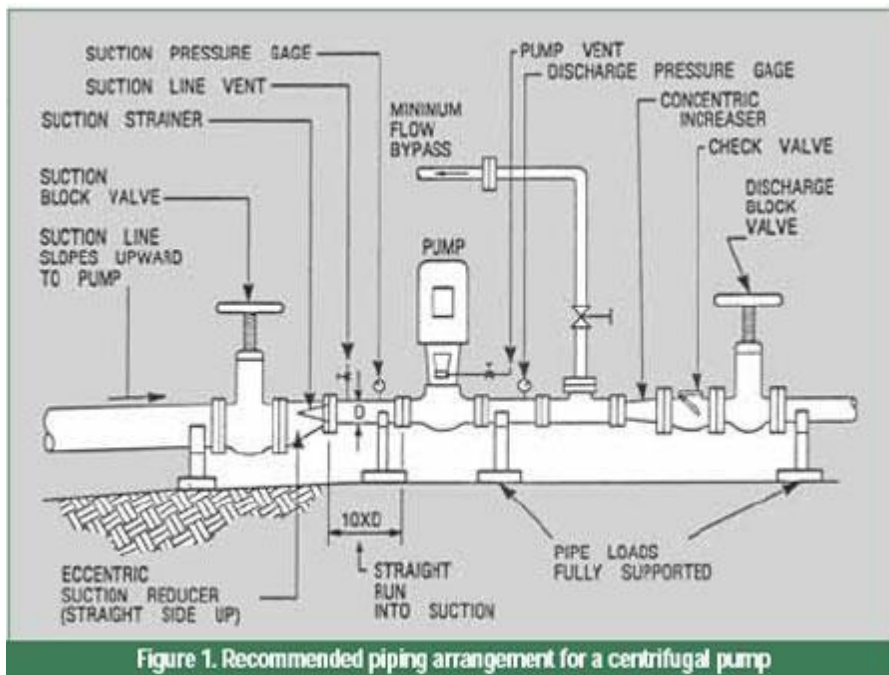

Laying pipe connection to the delivery side of a pump	
<b>DATE:</b>	<b>EX.NO.17</b>

Aim:

To connect the PVC / GI pipe with pipe fittings like valves, bends and tap.

Fittings and Components Required:

Pipes of different length

Gate valve

Tap

Elbows

Reducer

Tools required:

Pipe wrench, Hack saw, Die set, Hammer, Screw driver, Measuring tape.

Sequence of Operation:

1. Selection of pipes.
2. Threading of pipes.
3. Connection of the pipes with the pipe fittings

Working Steps:

- The required pipe connection layout is drawn.
- Two pipes of required lengths are taken and the ends are threaded using die set.
- The gate valve which is internally threaded is connected between two pipes. The other end of the pipe is connected with the elbow which is also internally threaded.
- A third pipe, with external threads is connected to the elbow for vertical extension.
- To this pipe another elbow is attached at the free end.
- The free end of the second elbow is connected with another pipe for horizontal extension.
- A reducer coupling, with internal threads is connected to the horizontal pipe.
- A tap is connected properly to the end of the reducer coupling.

Result:

Hence the required connection is obtained using required pipes and pipe fittings.

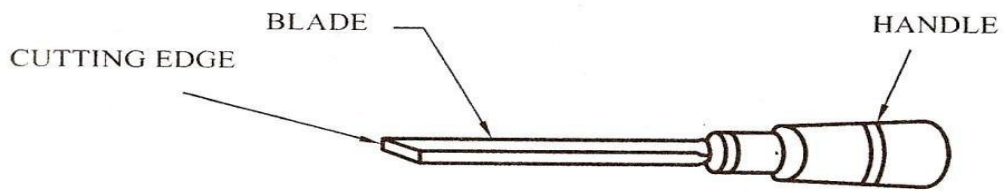
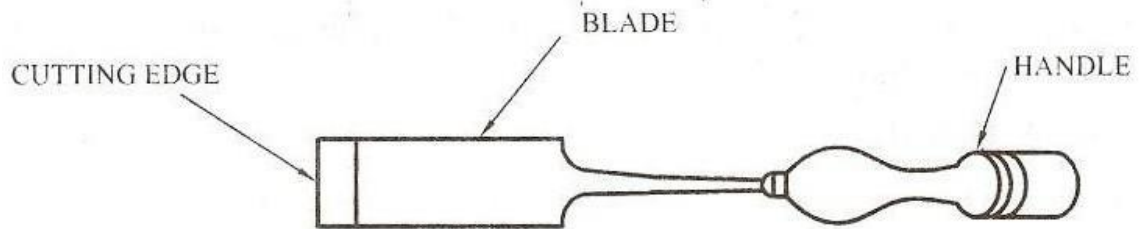

MORTISE CHISEL

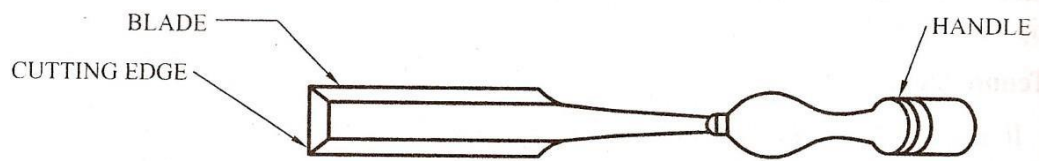

BEVELLED EDGE FIRMER CHISEL

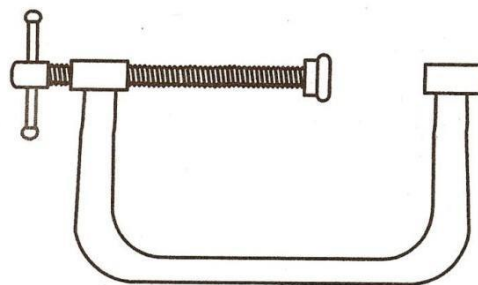

C-Clamp

**Introduction:**

A carpenter (builder) is a skilled craftsperson who performs carpentry. Carpenters work with wood to construct, install and maintain buildings, furniture, and other objects. The work may involve manual labor and work outdoors.

**Types of wood:**

The wood is generally classified into three types; Soft, Hard and Plywood

- 1. Soft wood:** It has straight fibers and it is weak but easy to work. Example: Deodar, Kail, Chir
- 2. Hard wood:** It is closed structure, heavy in weight, dark in colour, more durable. It is difficult to work. Example: Teak, Sal, Mango, Maple, Oak.
- 3. Plywood:** It has three layers i.e., Top face plys layer, Core layer and Bottom face plys layer. The top and bottom layers are called face plys layers. These two layers are bonded to the center core, which is thick and not of good quality.

**Wood Seasoning:**

Wood Seasoning is the process of removal of moisture from Timber. This can also be termed as the drying process of timber. Fresh timber has a very high quantity of moisture and hence is not useful for use in construction or for manufacture of furniture. In the seasoning process the moisture of the wood is brought down in the range of 8 - 15% based on the end application.

Following are the advantages of Seasoning:

1. No risk of fungal decay
2. Reduces weight
3. Improvement in Strength Properties
4. Increase in Nail and screw holding capacity
5. Improves Gluing capacity
6. Helps in Preservative Treatment
7. Wood exhibits better electrical and thermal Insulation properties



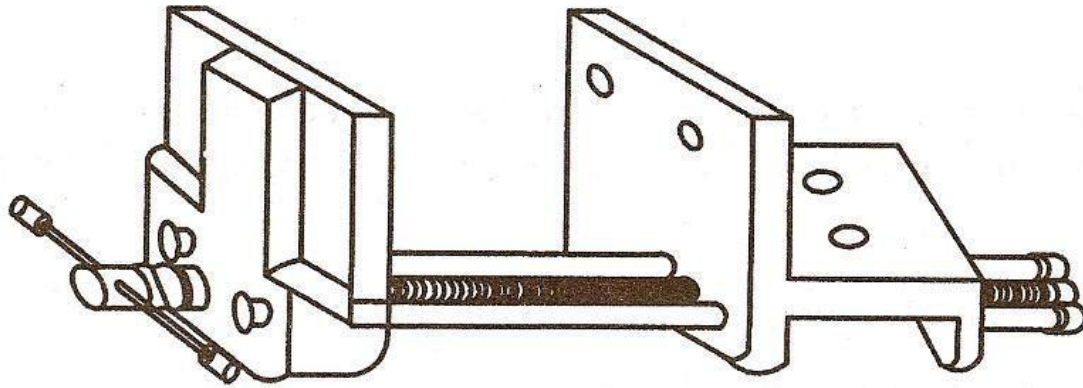

BENCH VICE

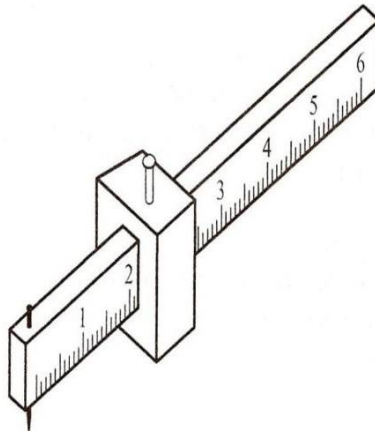

MARKING GAUGE

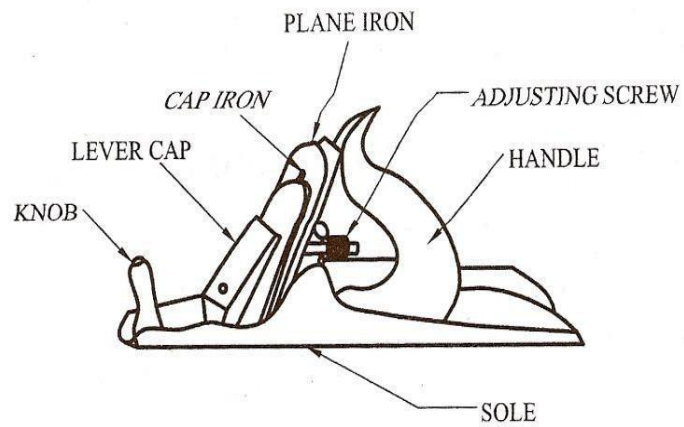

METAL JACK PLANE

## Carpentry Tools:

### 1. A Ball Peen Hammer:

A ball-peen hammer is a type of peening hammer used in woodworking. It is distinguished from a point-peen hammer or chisel-peen hammer by having a hemispherical head. Ball-peen hammers are divided into two classes: hard-faced and soft-faced. The head of a hard-faced hammer is made of heat treated forged high-carbon steel or alloy steel; it is harder than the face of a claw hammer. The soft-faced hammers are made from brass, lead, tightly wound rawhide, or plastic. These hammers usually have replaceable heads or faces, because they will deform, wear out, or break over time. They are used when there is the danger of damaging a striking surface.

### 2. Mallet:

A mallet is a kind of hammer, made of wood, with a relatively large head. Wooden mallet, usually used in carpentry to knock wooden pieces together or to drive dowels or chisels. A wooden mallet will not deform the striking end of a metal tool, as most metal hammers would, but it also reduces the force available to drive the cutting edge of a chisel.

### 3. Chisel:

They are particularly useful for cutting purpose with the help of mallet. It also has a strengthening piece called a ferrule which prevents the handle from splitting at the bottom when it is hit repeatedly by a mallet.

#### Types of Chisels

Chisels have a wide variety of uses. Many types of chisels have been devised, each specially suited to its intended use.

#### a) Mortise Chisel:

Thick, rigid blade with straight cutting edge and square sides to make mortises and similar joints.

#### b) Dovetail Chisel:

Made specifically for cutting dovetail joints. The different being the thickness of the body of the chisel, as well as the angle of the edges, permitting easier access to the joint.

#### c) Bevel Chisel:

Edged chisels are slightly undercut making them easy to push into corners. They are normally used for finishing dovetail joints.

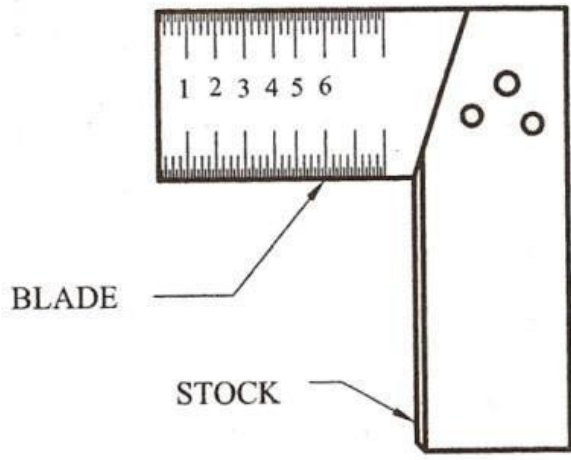

TRY SQUARE

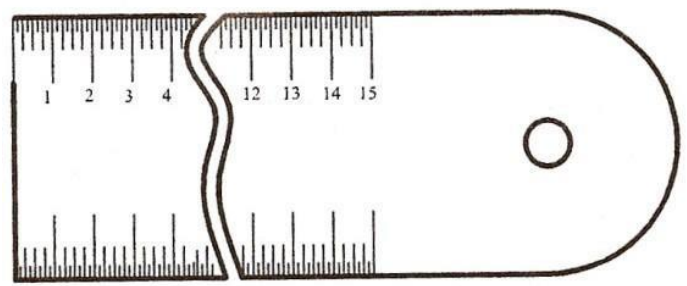

STEEL RULE

**d) Firmer Chisels:**

They have a blade with a rectangular cross-section. This means that they are stronger and can be used for tougher/heavier work.

**4. Try square:**

It is used for testing the flatness of the surfaces or whether the adjacent surfaces are at right angles to each other or not.

**5. Vice:**

A vice is a mechanical screw apparatus used for holding or clamping a work piece to allow work to be performed on it with tools such as saws, planes, drills, mills, screwdrivers, sandpaper, etc.

**6. C- Clamp:**

A C-clamp is a type of clamp device typically used to hold a wood or metal work piece, and are often used in, but are not limited to, carpentry and welding. These clamps are called "C" clamps because of their C shaped frame.

**7. Saw:**

A saw is used to cut the wood into pieces. It has different types as follows:

**a) Mitre saw :**

It is often referred to a large backsaw (20-30 inches or 60-90 cm) used either in a wooden mitre box or in a metal frame which allowed cutting mitres of any specified angle.

**b) Tenon saw:**

It has a parallel blade of width 60 mm to 100 mm, length 250 mm to 400 mm and 12 to 20 points or teeth per 25 mm length. The teeth are shaped like a cross cut saw, in form of an equilateral triangle.

**c) Rip Saw:**

It is used for cutting along the grains of wood. Its blade is about 700 mm long, and has 3 to 5 points or teeth per 25 mm length. The teeth of the rip saw have a series of chisel edge.

**8. Steel Rule:**

Steel rules, also called rulers, are essential for linear measurements in any shop. They can also be used as guides for laying out lines, and if rigid enough, for cutting. The thinner, more flexible rules can also be used to measure rounded or cambered work.

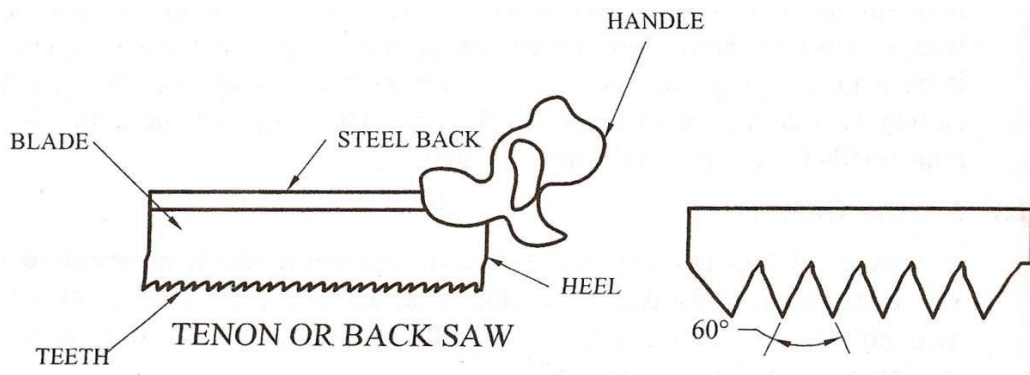
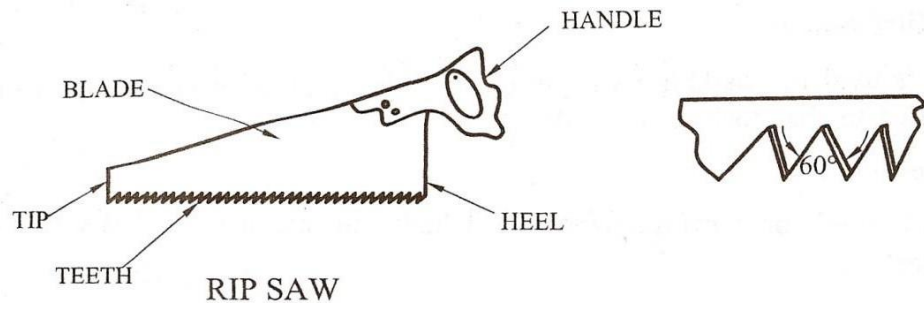

### **9. Marking Gauge:**

A marking gauge is used in woodworking and metalworking to mark out lines for cutting or other operations. In metalworking it can be known as a scratch gauge. The purpose of the gauge is to scribe a line parallel to a reference edge or surface. It is used in joinery and sheet metal operations.

### **10. Jack Plane:**

It is used to make the surface of wood smooth to get good surface finish. A large range of planes are available and they are used for different purposes. The body of a plane is made from high grade cast iron with the cutters being tungsten made from vanadium steel. Mainly there are two types: Wooden Jack Plane and Metal Jack Plane. Note that Metal Jack plane is used to get better surface finish.

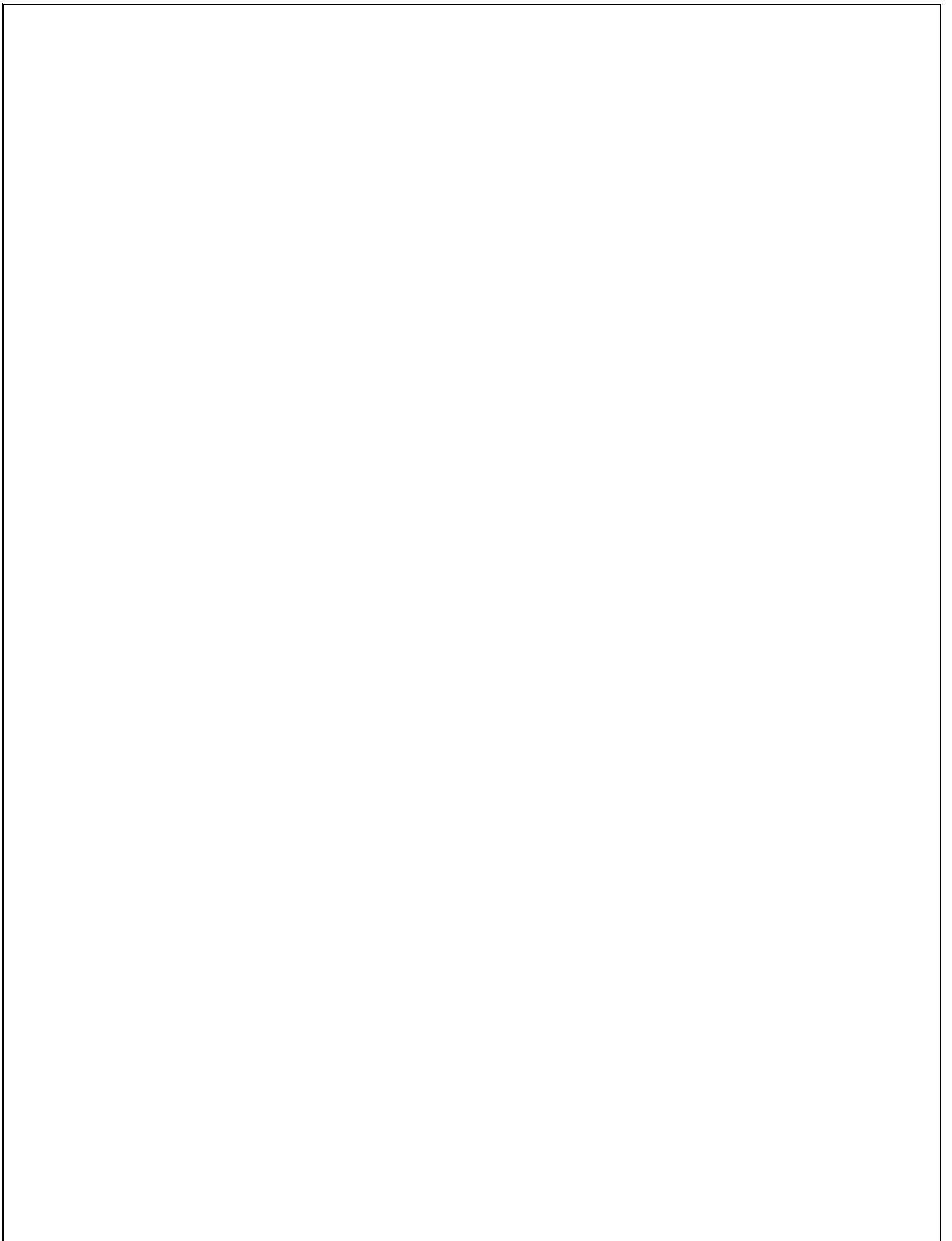

# CARPENTRY EXERCISES



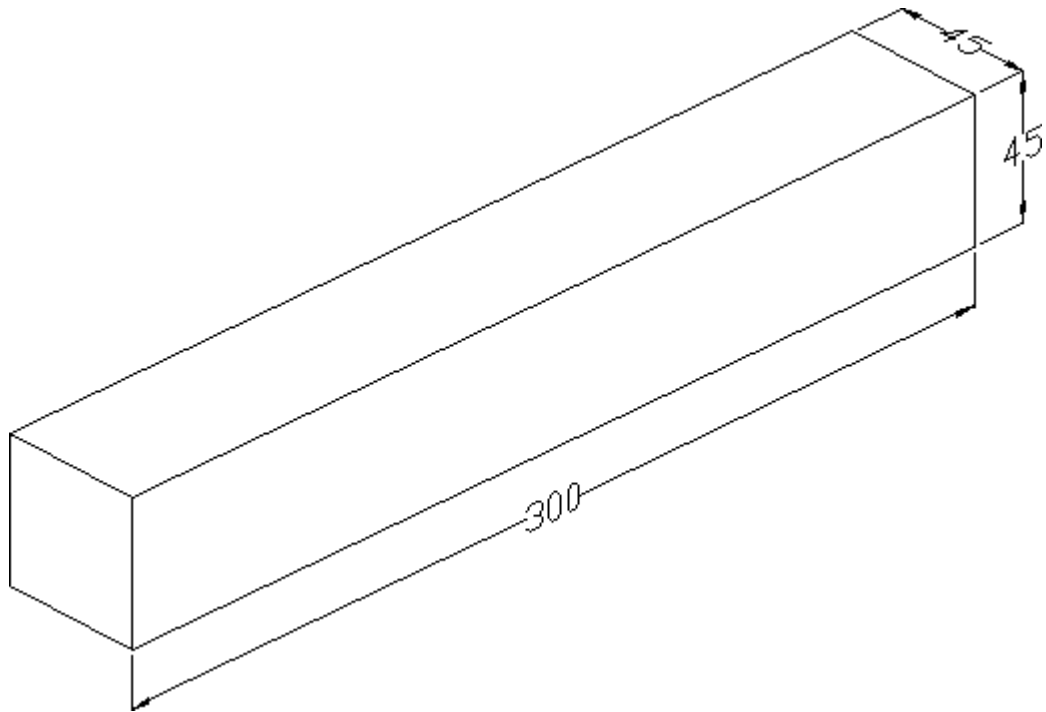

*All dimensions are in mm.*

<b>PLANNING &amp; SAWING</b>	
<b>DATE:</b>	<b>EX.NO.18</b>

**AIM:**

To plane the given workpiece to the required shape and dimension.

**Material Supplied:**

Wooden piece of size 300x50x50 mm

**Tools Required:**

Steel rule, Marking Gauge, Try-Square, Carpentry Vice, Jack Plane and Tennon Saw

**Sequence of Operation:**

- a) Rough Planning
- b) Marking
- c) Cutting (or) Sawing
- d) Finish planning

**Working Steps:**

1. The given job is checked to ensure its correct size.
2. The job is clamped rigidly in the carpentry vice and any two adjacent surfaces are planned using jack plane to the given specifications.
3. Using try square the right angle of the work piece is checked.
4. The required dimensions are marked on the job using steel rule and marking gauge.
5. By means of Jack plane, the job is planned such that it should have accurate dimensions.
6. The finished job is checked for right angle using try square and dimensions using steel rule.

**RESULT:**

Hence the given work piece is planned to the desired shape and size.

# TEE LAP JOINT

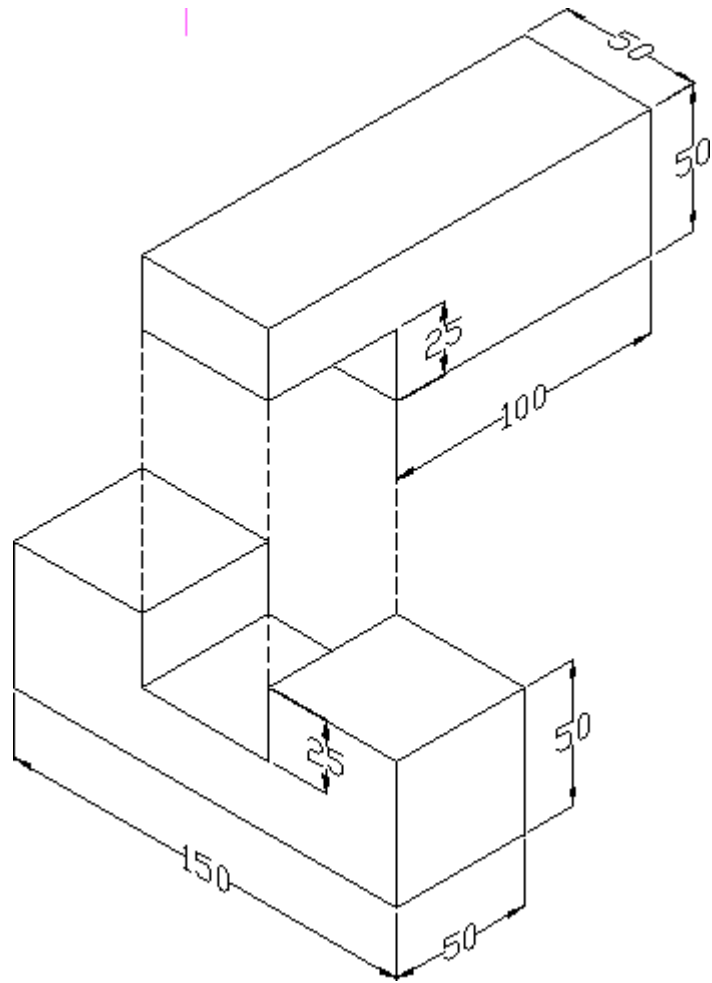

*All dimensions are in mm.*

<b>TEE – LAP JOINT</b>	
<b>DATE:</b>	<b>EX.NO.19</b>

**AIM:**

To make tee-lap joint from the given workpiece to the required shape and dimension.

**Material Supplied:**

Wooden piece of size 300x50x50 mm

**Tools Required:**

Steel rule, Marking Gauge, Try-Square, Carpentry Vice, Jack Plane, Tennon Saw, Rib Saw, Mallet and Chisels

**Sequence of Operation:**

- a. Rough Planning
- b. Marking
- c. Cutting (or) Sawing
- d. Chiselling
- e. Finish planning

**Working Steps:**

1. The given job is checked to ensure its correct size.
2. The job is clamped rigidly in the carpentry vice and any two adjacent surfaces are planned using jack plane to the given specifications.
3. Using try square the right angle of the workpiece is checked.
4. All the four sides are planned to get smoother and finished surfaces at right angles to each other.
5. The job is cut into two halves using the Rib saw. Then proper marking is done for T-Lap joint on the two pieces using steel rule and marking gauge.
6. Using tennon saw and firmer chisel the unwanted portions are removed as per the drawing in both the pieces.
7. The two pieces are assembled to check proper fitting..
8. The finished job is checked for its accuracy using try square and steel rule.

**RESULT:**

Hence the required Tee-lap joint is obtained from the given work piece

DOVETAIL JOINT

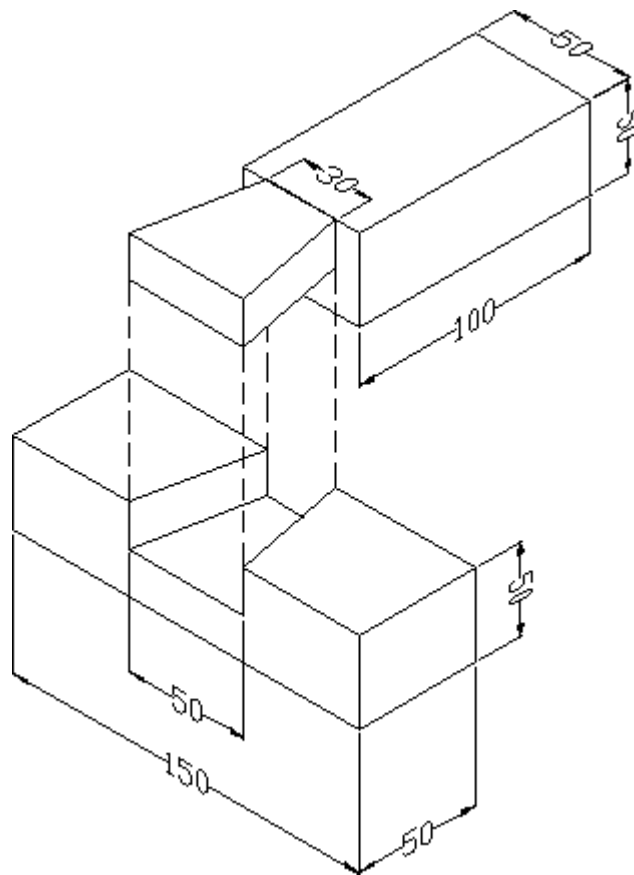

*All dimensions are in mm.*

<b>DOVE TAIL JOINT</b>	
<b>DATE:</b>	<b>EX.NO.20</b>

**AIM:**

To make dovetail joint from the given workpiece to the required shape and dimension.

**Material Supplied:**

Wooden piece of size 300x50x50 mm

**Tools Required:**

Steel rule, Marking Gauge, Try-Square, Carpentry Vice, Jack Plane, Tennon Saw/ Rib Saw, Mallet and Chisels

**Sequence of Operation:**

1. Rough Planning
2. Marking
3. Cutting (or) Sawing
4. Chiseling
5. Finish planning

**Working Steps:**

1. The given job is checked to ensure its correct size.
2. The job is clamped rigidly in the carpentry vice and any two adjacent surfaces are planned using jack plane to the given specifications.
3. Using try square the right angle of the work piece is checked.
4. All the four sides are planned to get smoother and finished surfaces at right angles to each other.
5. The job is cut into two halves using the Rib saw. Then proper marking is done for dovetail joint on the two pieces using steel rule and marking gauge.
6. Using tennon saw and firmer chisel the unwanted portions are removed as per the drawing in both the pieces.
7. The two pieces are assembled to check proper fitting..
8. The finished job is checked for its accuracy using try square and steel rule.

**RESULT:**

Hence the required dovetail joint is obtained from the given work piece

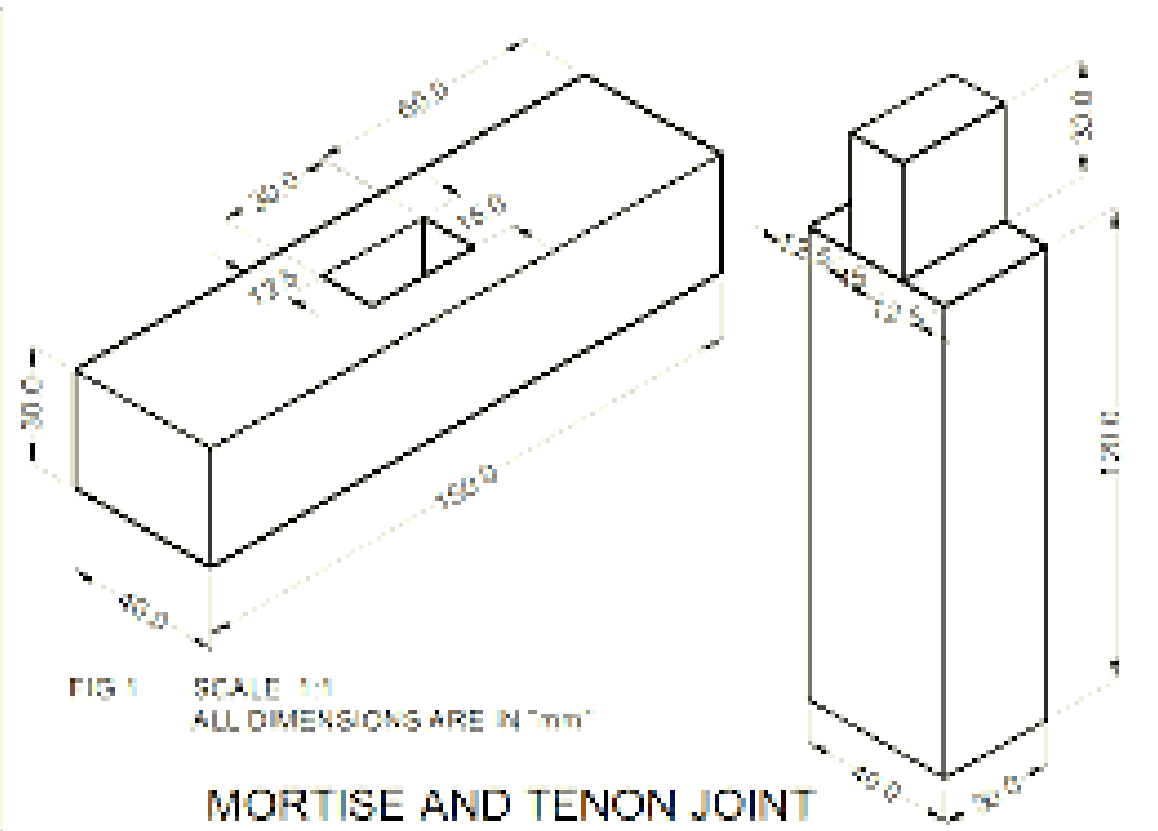

<b>MORTISE AND TENON JOINT</b>	
<b>DATE:</b>	<b>EX.NO.21</b>

**AIM:**

To make dovetail joint from the given workpiece to the required shape and dimension.

**Material Supplied:**

Wooden piece of size 300x50x50 mm

**Tools Required:**

Steel rule, Marking Gauge, Try-Square, Carpentry Vice, Jack Plane, Tennon Saw/ Rib Saw, Mallet and Chisels

**Sequence of Operation:**

- a. Rough Planning
- b. Marking
- c. Cutting (or) Sawing
- d. Chiseling
- e. Finish planning

**Working Steps:**

1. The given job is checked to ensure its correct size.
2. The job is clamped rigidly in the carpentry vice and any two adjacent surfaces are planned using jack plane to the given specifications.
3. Using try square the right angle of the work piece is checked.
4. All the four sides are planned to get smoother and finished surfaces at right angles to each other.
5. The job is cut into two halves using the Rib saw. Then proper marking is done for dovetail joint on the two pieces using steel rule and marking gauge.
6. Using tennon saw and firmer chisel the unwanted portions are removed as per the drawing in both the pieces.
7. The two pieces are assembled to check proper fitting..
8. The finished job is checked for its accuracy using try square and steel rule.

**RESULT:**

Hence the required mortise and tenon joint is obtained from the given work piece



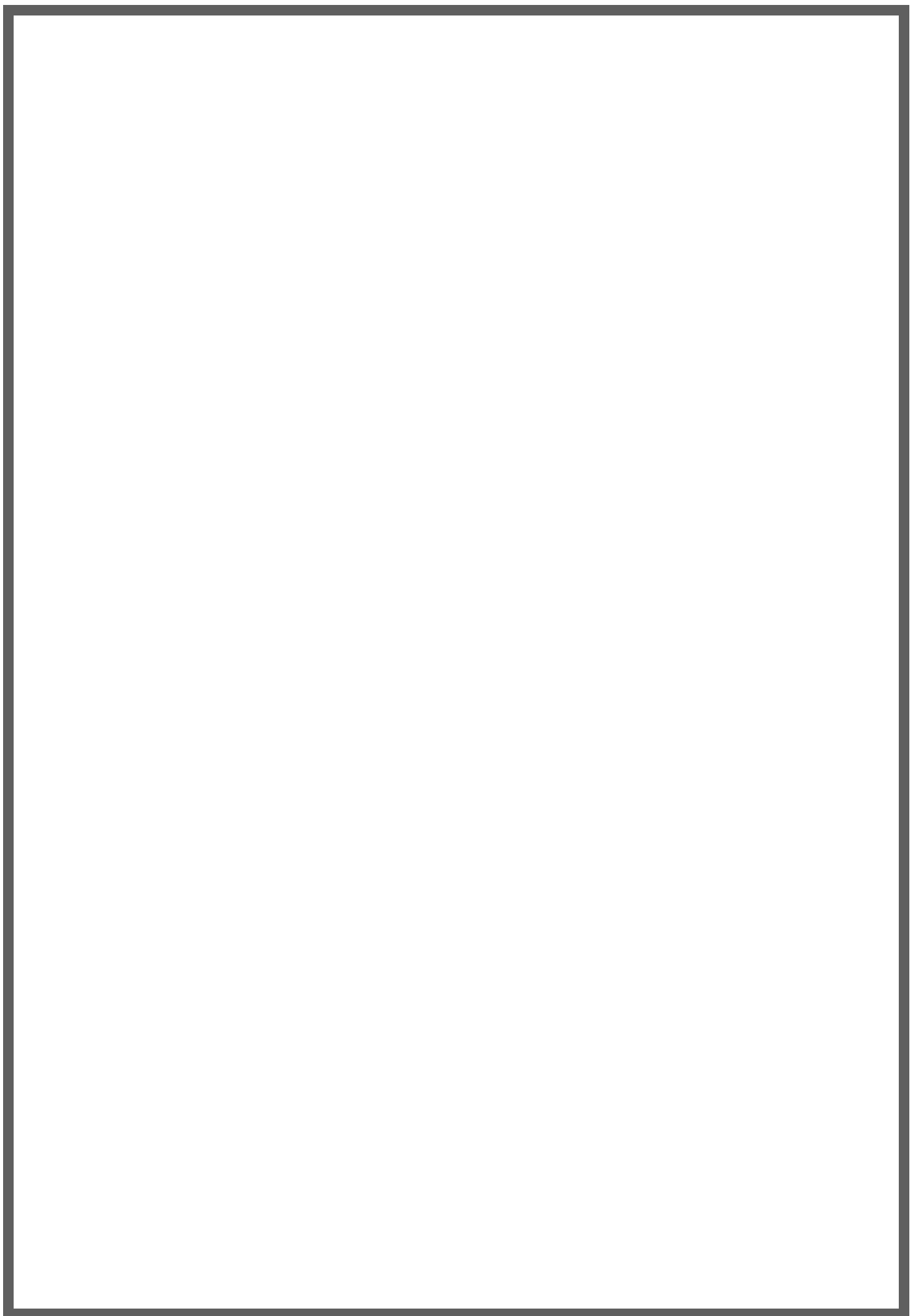

Studying joints in door panels and wooden furniture	
<b>DATE:</b>	

Here we will look at a list of the most common joinery techniques. As you will see below, there are many different ways to join two pieces of wood together, each with their own set of advantages and disadvantages which are also discussed. These joints will be visible in the furniture in your home and garden. So have a look at the chairs, tables, doors, cabinets inside your home or the garden furniture or timber gates outside your home and see which joinery techniques are being used.

Butt Joint:

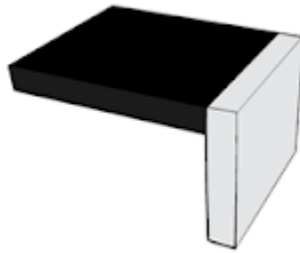

The butt joint is the simplest but also the weakest type of joint. It is created by simply butting two boards together (hence the name) and attaching them using glue or with a nail or screw for extra strength. This joinery application is usually used to glue narrow boards side to side to form one wide panel, such as a cabinet door or a table top. Butt joints are not commonly used in furniture construction, due to their weaknesses and for their lack of any obvious aesthetic quality.

Box Joint:

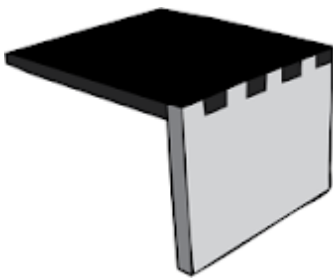

The box joint, also called a finger joint or comb joint, connects two boards at the corners. It is made by cutting a set of complementary rectangular cuts in two pieces of wood, which are then glued. It is very strong and is often utilized in boxes, such as blanket chests and jewelry boxes, because of its decorative look. The strength of a finger joint comes from the long-grain to long-grain contact between the fingers, which provides a solid gluing surface. The number of contact points also allows for more gluing surface as opposed to a butt joint

Dovetail Joint:

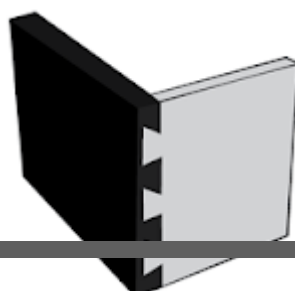

The dovetail is one of the strongest, most beautiful, and most complex joinery techniques that woodworkers employ. It is one of the strongest joints because of how the side piece prevents the front piece from ever being pulled, due to their trapezoidal shape away and because the greater number of contact points also allows for more gluing surface. A series of pins cut to extend from the end of one board interlock with a series of tails cut into the end of another board. There are many variations of dovetails, such as a half-blind, through, and sliding dovetail.

#### Mortise & Tenon Joint:

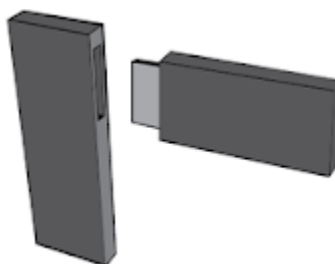

The mortise and tenon joint is the one of the strongest and most widely used joinery methods in woodworking. A mortise is a cavity cut into a timber to receive a tenon which is a projection on the end of another timber for insertion into the mortise. The joint may be glued, pinned, or wedged to lock it in place. In its basic form it is both simple and strong although there are a multitude of applications and variations that are employed throughout woodworking. This joint is a staple in the building of chairs, tables, cabinet doors, and paneling.

#### Dowel Joint:

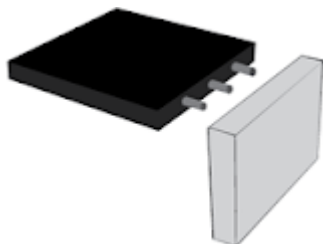

The doweled joint is merely a butt joint that uses wooden dowels (A dowel is a solid cylindrical rod, usually made of wood) to help align and strengthen the bond between two boards. Often times a doweled joint is made into a very visually appealing joint by passing the dowels completely through the side piece allowing them to show through and sanding them flush with the surface. A well-made dowel joint is as strong as a mortise and tenon joint.

### Half-Lap Joint:

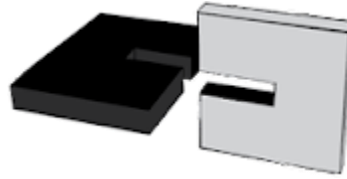

A half-lap joint is a very strong and very visually appealing joint which is merely the process of joining two pieces of wood together by removing half of the width from each board so that they completely overlap each other when joined. They are quick and easy to make and provide reasonable strength through good long grain to long grain gluing surface. The shoulders provide some resistance to diagonal distortion caused by twisting or pressure. They may also be reinforced with dowels to totally eliminate any distortion.

### Frame & Panel Joint:



The frame and panel joint is the primary method of constructing cabinet doors. Each panel consists of two vertical stiles running the complete height of the door, two rails that run the overall width of the door minus the width of the two stiles, and a center panel. This joinery technique creates a large panel that is unaffected by environmental changes, because the center panel floats between the rails and stiles, and is able to expand and contract without affecting the other pieces. There are hundreds of different router details that can be used on the rails, stiles, and doors, to create a look as fancy or as simple as desired.

### Mitre Joint:



The miter joint is a simple and easy way to connect any two pieces of wood together at any angle necessary. Simply cut each edge to half the overall angle, usually at a 45 degree angle, to form a corner or 90 degree angle, and join together using glue, nails, or screws. The miter joint, like the butt joint, is not very strong, but is quick and easy to make. In order to strengthen a mitre joint a spline joint can be added. Common applications of the mitre joint include picture frames and moulding.

### Rebate and Dado Joints:



Rebate and Dado joints are simple joints that create an incredibly strong bond by inserting one piece of wood, a rebate, into a groove, a Dado, in another piece of wood. In addition to increasing the glue surface, the rabbet also provides support and alignment for the two adjoining pieces. This joint is the backbone of cabinet box and bookcase construction. Just about any variation of this joint can be cut with either a table saw (with dado blade) and/or a router (with dado jig).

### Spline Joint:

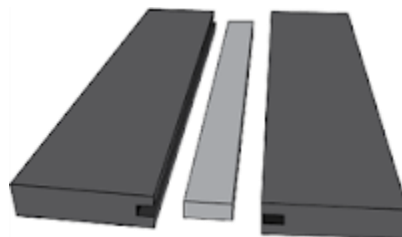

A spline joint is achieved by inserting a strip of wood into two corresponding grooves cut into two matching boards and is really an extended biscuit joint. A spline joint is also similar to a tongue and groove joining system. The difference is that the spline is essentially forming a tongue for both grooves. It is often traditionally joined with glue. A spline joint is often used to strengthen a butt or mitre joint and can add a lot of visual appeal by using contrasting colours of woods.

**DATE:**

A truss is essentially a triangulated system of straight interconnected structural elements. The most common use of trusses is in buildings, where support to roofs, the floors and internal loading such as services and suspended ceilings, are readily provided. The main reasons for using trusses are:

- Long span
- Lightweight
- Reduced deflection (compared to plain members)
- Opportunity to support considerable loads.

### Types of trusses

Trusses comprise assemblies of tension and compression elements. Under gravity loads, the top and bottom chords of the truss provide the compression and tension resistance to overall bending, and the bracing resists the shear forces. A wide range of truss forms can be created. Each can vary in overall geometry and in the choice of the individual elements. Some of the commonly used types are shown below.

#### Pratt truss ('N' truss)

Pratt trusses are commonly used in long span buildings ranging from 20 to 100 m in span. In a conventional Pratt truss, diagonal members are in tension for gravity loads. This type of truss is used where gravity loads are predominant (see below left). An alternative Pratt truss is shown (below right) where the diagonal members are in tension for uplift loads. This type of truss is used where uplift loads are predominant, which may be the case in open buildings such as aircraft hangers.

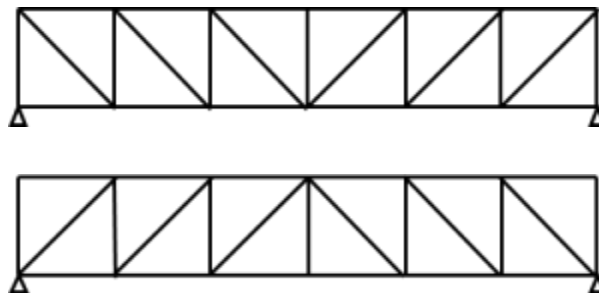

It is possible to add secondary members (as illustrated below left) to:

- Create intermediate support points for applied loads
- Limit the buckling length of members in compression (although in a 2D truss, the buckling length is only modified in one axis).

For the Pratt truss and any of the types of truss mentioned below, it is possible to provide either a single or a double slope to the upper chord of a roof supporting truss. An example of a double (duo-pitch) Pratt truss is shown below.

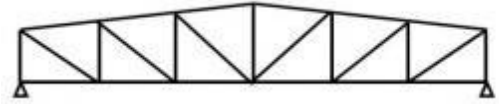

### Warren truss

In this type of truss, diagonal members are alternatively in tension and in compression. The Warren truss has equal length compression and tension web members, and fewer members than a Pratt truss. A modified Warren truss may be adopted where additional members are introduced to provide a node at (for example) purlin locations.

Warren trusses are commonly used in long span buildings ranging from 20 to 100 m in span.

This type of truss is also used for the horizontal truss of gantry/crane girders.



### North light truss

North light trusses are traditionally used for short spans in industrial workshop-type buildings. They allow maximum benefit to be gained from natural lighting by the use of glazing on the steeper pitch which generally faces north or north-east to reduce solar gain. On the steeper sloping portion of the truss, it is typical to have a truss running perpendicular to the plane of the North Light truss, to provide large column-free spaces.

The use of north lights to increase natural daylighting can reduce the operational carbon emissions of buildings although their impact should be explored using dynamic thermal modelling. Although north lights reduce the requirement for artificial lighting and can reduce the risk of overheating, by increasing the volume of the building they can also increase the demand for space heating. Further guidance is given in the Target Zero Warehouse buildings design guide .

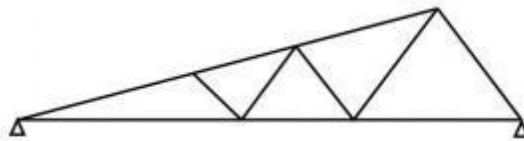

### Saw-tooth truss

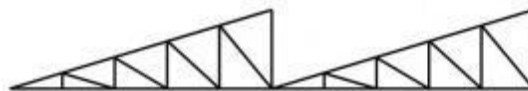

A variation of the North light truss is the saw-tooth truss which is used in multi-bay buildings. Similar to the North light truss, it is typical to include a truss of the vertical face running perpendicular to the plane of the saw-tooth truss.

### Fink truss

The Fink truss offers economy in terms of steel weight for short-span high-pitched roofs as the members are subdivided into shorter elements. There are many ways of arranging and subdividing the chords and internal members.

This type of truss is commonly used to construct roofs in houses.

